

FIRESTOP CENTRE LIMITED

FIRE ASSESSMENT REPORT

*Service penetrations protected by Protecta EX Mortar
in accordance with AS 1530.4:2014 and
AS 4072.1:2005*



Report number: 53619700C

Revision: R4.4 Reference number: FAS210027, 260234

Issued date: 2 April 2026 Expiry date: 30 April 2031



JENSEN HUGHES

Quality management

Revision	Date	Revision Description
53619700-C.1	Issue: 16 Jul 2018	Initial issue.
		Prepared Reviewed Authorised
		Mahmoud Akl Omar Saad N/A
53619700C.2	Issue: 14 Sep 2018	Revised to include graphite table.
		Prepared Reviewed Authorised
		Mahmoud Akl Omar Saad N/A
53619700C.3	Issue: 18 Sep 2018	Revised for typographical amendments.
		Prepared Reviewed Authorised
		Mahmoud Akl Omar Saad N/A
53619700C R4.0	Issue: 26 Mar 2021	Revised to include additional test data and additional assessed systems.
		Prepared Reviewed Authorised
		Sukhi Sendanayake Mahmoud Akl Mahmoud Akl
53619700C R4.1	Issue: 23 Apr 2021	Revised to address comments from report sponsor.
		Prepared Reviewed Authorised
		Sukhi Sendanayake Mahmoud Akl Mahmoud Akl
53619700C R4.2	Issue: 17 May 2021	Report re-issued after addressing further comments from report sponsor.
		Prepared Reviewed Authorised
		Sukhi Sendanayake Mahmoud Akl Mahmoud Akl
53619700C R4.3	Issue: 25 Mar 2026	Report revalidated for another 5 years.
		Prepared Reviewed Authorised
		Edward Kwok Omar Saad Omar Saad
53619700C R4.4	Issue: 02 Apr 2026	Report updated to:
		+ Correct revision number. + Test sponsor name has been revised to Firestop Centre Limited.
	Expiry: 30 April 2031	Prepared Reviewed Authorised
		Edward Kwok Henry Brammer Henry Brammer

Jensen Hughes Fire Testing Pty Ltd
ABN 81 050 241 524
Formerly Warringtonfire Australia Pty Ltd¹

¹ Warringtonfire Australia Pty Ltd was acquired by Jensen Hughes in December 2023. Jensen Hughes Fire Testing Pty Ltd is not affiliated, associated, authorised, or endorsed by Warringtonfire Australia Pty Ltd, Warringtonfire Testing and Certification Limited or its "Warringtonfire" or "Certifire" brands.

Executive summary

This report documents the findings of the assessment undertaken to determine the fire resistance levels (FRL) of service penetrations protected with Protecta EX Mortar in accordance with AS 1530.4:2014 and AS 4072.1:2005 (R2016).

Protecta EX Mortar is a gypsum-based mortar material, used to reinstate the fire resistance performance of wall and floor constructions where they have been provided with apertures for the penetrations of multiple services such as cables, trays and metallic, plastic and composite cables. It is supplied as a dry material and is mixed with water to the required ratio prior to installation. When mixed, it is self-supporting in a wall and floor orientation and may be used with or without a permanent mineral fibre backing material depending upon the required application and FRL.

The analysis in sections 5.0 to 7.0 of this report found that the proposed systems, together with the described variations, will achieve the FRL shown in this report – in accordance with AS 1530.4:2014 and AS 4072.1:2005 (R2016).

The variations and outcome of this assessment are subject to the limitations and requirements described in sections 2.0, 3.0 and 8.0 of this report. The results of this report are valid until 30 April 2031.

Table 1 Variations and assessment outcome

Item	Reference tests	Variations	Fire resistance levels (FRL)
1.	As given in Appendix B	Determine the fire resistance performance in accordance with AS 1530.4:2014 and AS 4072.1:2005.	As provided in section 5.0.
2.		Assess the performance of various types and sizes of cables, metallic pipes, composite pipes and plastic pipes protected with Protecta EX Mortar and other supplementary fire sealing systems.	As provided in section 6.0.
3.		Extension of FRLs to intermediate pipe sizes based on the testing of the maximum and minimum pipe size.	
4.		<p>It is proposed that the separating elements are varied as follows:</p> <ul style="list-style-type: none"> + Increase in aperture size for fire seals filled with Protecta EX Mortar + Test results from floors as applicable to walls + The plasterboard wall partition tested shall include the option of lining with two layers of 13 mm thick fire grade plasterboard that has otherwise been tested or assessed as a wall to achieve a FRL -/120/120 on each side of steel or timber framed wall. + Applying test results obtained to masonry, AAC or concrete walls + Wall thickness is reduced from 150 mm to 100 mm for section 6.3.5 and floor thickness is reduced from 150 mm as tested to 100 mm for assessed systems in sections 6.4.5 and 6.4.7. + It is proposed that the integrity rating achieved for insulated pipes can be applied to uninsulated pipes as shown in sections 6.3.3, 6.3.8, 6.4.2 and 6.4.6. 	As provided in section 7.0.

Table of contents

Quality management	2
Executive summary	3
1.0 Introduction.....	6
2.0 Framework for the assessment	6
2.1 Assessment approach	6
2.2 Compliance with the National Construction Code	7
2.3 Declaration	7
3.0 Requirements and limitations of this assessment	8
4.0 Description of the specimen and variations	9
4.1 Description of assessed systems	9
4.2 Referenced test data	11
4.3 Variations to the tested systems	12
4.4 Test standard	12
4.5 Reference standard	12
5.0 Assessment 1 – Applicability of test results in accordance with AS 1530.4:2014.....	13
5.1 Description of variation	13
5.2 Methodology.....	13
5.3 Assessment.....	13
5.4 Application of test data to AS 1530.4:2014.....	16
6.0 Assessment 2 – Fire resistance performance of services protected with Protecta EX Mortar	17
6.1 Description of variation	17
6.2 Methodology.....	17
6.3 Rigid wall constructions according to section 4.1 dot point 2 with wall thickness of minimum 150 mm.....	18
6.4 Rigid floor constructions according to 4.1 dot point 2 with floor thickness of minimum 100 mm 32	
6.5 Rigid floor constructions according to section 4.1 dot point 2 with floor thickness of minimum 120 mm.....	84
6.6 Rigid floor constructions according to section 4.1 dot point 2 with floor thickness of minimum 150 mm.....	86
6.7 Flexible and rigid wall constructions according to section 4.1 dot point 2 with wall thickness of minimum 100 mm	92
7.0 Assessment 3 – Assessment of specific variations	108
7.1 Description of variation	108
7.2 Methodology.....	108
7.3 Assessment.....	108
8.0 Validity.....	111
Appendix A Drawings and additional information	112
Appendix B Summary of supporting test data	113

B.1	Test report – WF 416697	113
B.2	Test report – WF 394948	114
B.3	Test report – 405610	115
B.4	Test report – WF 405532 REVISION A	116
B.5	Test report – WF 400805	118
B.6	Test report – WF 400806	119
B.7	Test report – WF 397686 Revision A	120
B.8	Test report – WF 392115	121
B.9	Test report – WF 19324A	122
B.10	Test report – WF 375797	124
B.11	Test report – WF 375799A	125
B.12	Test report – WF 375799B	127
B.13	Test report – WF 379319	129
B.14	Test report – WF 380963	131
B.15	Test report – WF 382337	133

1.0 Introduction

This report documents the findings of the assessment undertaken to determine the fire resistance level (FRL) of service penetrations protected with Protecta EX Mortar in accordance with AS 1530.4:2014² and AS 4072.1:2005 (R2016)³. AS 4072.1:2005 in this document refers to AS 4072.1:2005 (R2016).

This report may be used as evidence of suitability in accordance with the requirements of the relevant National Construction Code (NCC) to support the use of the material, product, form of construction or design as given within the scope of this assessment report. It also references test evidence for meeting deemed-to-satisfy (DTS) provisions of the NCC that apply to the assessed systems.

This assessment was carried out at the request of Firestop Centre Limited. The sponsor details are included in Table 2.

Table 2 Sponsor details

Sponsor	Address
Firestop Centre Limited	Unit J, 657 Great South Road, Penrose, Auckland 1061, New Zealand

2.0 Framework for the assessment

2.1 Assessment approach

An assessment is a professional opinion about the expected performance of a component or element of structure subjected to a fire test.

No specific framework, methodology, standard or guidance documents exists in Australia for undertaking these assessments. We have therefore followed the 'Guide to undertaking technical assessments of the fire performance of construction products based on fire test evidence' prepared by the Passive Fire Protection Forum (PFPF) in the UK in 2021⁴.

This guide provides a framework for undertaking assessments in the absence of specific fire test results. Some areas where assessments may be offered are:

- + Where a modification is made to a construction which has already been tested
- + The interpolation or extrapolation of results of a series of fire resistance tests, or utilisation of a series of fire test results to evaluate a range of variables in a construction design or a product
- + Where, for various reasons – eg size or configuration – it is not possible to subject a construction or a product to a fire test.

Assessments can vary from relatively simple judgements on small changes to a product or construction through to detailed and often complex engineering assessments of large or sophisticated constructions.

² Standards Australia, 2014, Methods for fire tests on building materials, components and structures – Part 4: Fire-resistance tests for elements of construction, AS 1530.4:2014, Standards Australia, NSW.

³ Standards Australia, 2016, Components for the protection of openings in fire-resistant separating elements: Service penetrations and control joints, AS 4072.1:2005 (R2016), Standards Australia, NSW.

⁴ Passive Fire Protection Forum (PFPF), 2021, Guide to undertaking technical assessments of the fire performance of construction products based on fire test evidence, Passive Fire Protection Forum (PFPF), UK.

This assessment uses established empirical methods and our experience of fire testing similar products to extend the scope of application by determining the limits for the design and performance based on the tested constructions and performances obtained. The assessment is an evaluation of the potential fire resistance performance of the elements in accordance with AS 1530.4:2014 and assessed in accordance with AS 4072.1:2005.

This assessment has been written in accordance with the general principles outlined in EN 15725:2023⁵ for extended application on the fire performance of construction products and building elements: Principle of EXAP standards and EXAP reports.

This assessment has been written using appropriate test evidence generated at accredited laboratories to the relevant test standard. The supporting test evidence has been deemed appropriate to support the manufacturer's stated design.

2.2 Compliance with the National Construction Code

This assessment report has been prepared to meet the evidence of suitability requirements of the NCC 2022⁶ under A5G3(1)(d). It references test evidence for meeting deemed-to-satisfy (DTS) provisions of the NCC under A5G5 for fire resistance level that apply to the assessed systems based on Specifications 1 and 2 for fire resistance for building elements.

The proposed details and systems (building elements) in this report are confirmed to be assessed, without the aid of an active fire suppression system, based on prototype tests that are equivalent to or more severe than a standard fire test as specified in section 4.4, in accordance with NCC 2022 S1C2(b). It is also confirmed that the differences between the proposed systems and details compared to the tested prototypes are considered minor in accordance with NCC 2022 S1C2(c).

This assessment report may also be used to demonstrate compliance with the requirements for evidence of suitability under the relevant sections of previous versions of the NCC.

2.3 Declaration

The 'Guide to undertaking technical assessments of the fire performance of construction products based on fire test evidence' prepared by the PFPF in the UK requires a declaration from the client. By accepting our fee proposal on 13 February 2026, Firestop Centre Limited confirmed that:

- + To their knowledge, the variations to the component or element of structure, which is the subject of this assessment, have not been subjected to a fire test to the standard against which this assessment is being made.
- + They agree to withdraw this assessment from circulation if the component or element of structure is the subject of a fire test by a test authority in accordance with the standard against which this assessment is being made and the results are not in agreement with this assessment.
- + They are not aware of any information that could adversely affect the conclusions of this assessment and – if they subsequently become aware of any such information – they agree to ask the assessing authority to withdraw the assessment.

⁵ European Committee for Standardization, 2023, Extended application on the fire performance of construction products and building elements: Principle of EXAP standards and EXAP reports, EN 15725:2023, European Committee for Standardization, Brussels, Belgium.

⁶ National Construction Code Volumes One and Two - Building Code of Australia 2022, Australian Building Codes Board, Australia.

3.0 Requirements and limitations of this assessment

- + The scope of this report is limited to an assessment of the variations to the tested systems described in section 4.3.
- + This report details the methods of construction, test conditions and assessed results in accordance with AS 1530.4:2014.
- + The results of this assessment are applicable to fire exposure from either side for the assessed wall systems and fire exposure from below for the assessed floor systems.
- + In systems where insulation installed on metallic and composite pipes is interrupted, it has been established that the insulation does not contribute to the integrity rating of the system. Therefore, assuming insulation is zero, the integrity rating achieved must be maintained when such systems are used on uninsulated pipes.
- + While it is recommended that for the elastomeric pipe insulation to be classified B-s3 as tested, the achieved results can be extended to cover an insulation material not deemed combustible as determined by AS 1530.1:2024⁷.
- + This report relies on test evidence and applies only to the specific specimens tested. It does not verify ongoing compliance or the performance of future production batches.
- + This assessment report has been prepared based on the fire resistance performance and condition of the products/systems at the time they were tested. Any deterioration of fire resistance performance due to external factors including but not limited to passage of time and exposure to elements – is not considered in this report.
- + Jensen Hughes has provided this report on the fire performance of building elements in a controlled laboratory setting, strictly within the parameters allowed by the test standards and building regulations. The outcomes of this report are intended to assist in verifying the suitability of the product or system for practical use in specific applications.
- + This report is only valid for the assessed systems and must not be used for any other purpose. Any changes with respect to size, construction details, loads, stresses, edge or end conditions – other than those identified in this report – may invalidate the findings of this assessment. If there are changes to the system, a reassessment will need to be done by an Accredited Testing Laboratory (ATL) that is accredited to the same nominated standards of this report.
- + This report has been prepared using information provided by others. Jensen Hughes has not verified the accuracy and/or completeness of that information and will not be responsible for any errors or omissions that may have been incorporated into this report as a result.
- + This assessment is based on the proposed systems being constructed under comprehensive quality control practices and following appropriate industry regulations and Australian Standards on quality of materials, design of structures, guidance on workmanship and expert handling, placing and finishing of the products on site. These variables are beyond the control and consideration of this report.

⁷ Standards Australia, 2024, Methods for fire tests on building materials, components and structures – Part 1: Combustibility test for materials, AS 1530.1:2024, Standards Australia, NSW.

4.0 Description of the specimen and variations

4.1 Description of assessed systems

Protecta EX Mortar is a gypsum-based mortar material, used to reinstate the fire resistance performance of wall and floor constructions where they have been provided with apertures for the penetrations of multiple services. It is supplied as a dry material and is mixed with water to the required ratio prior to installation. When mixed, it is self-supporting in a wall and floor orientation and may be used with or without a permanent mineral fibre backing material depending upon the required application and FRL.

Protecta FR Pipe Wraps are required to be used in conjunction with Protecta EX Mortar depending upon the required application and FRL.

1. The intended use of Protecta EX Mortar is to reinstate the fire resistance performance of flexible wall, rigid wall and floor constructions where they are penetrated by various cables, trays and metallic, plastic and composite pipes.
2. The specific elements of construction that the Protecta EX Mortar may be used to provide a penetration seal in, are as follows:
 - a. Flexible walls: The wall must have a minimum thickness of 75 mm or as otherwise specified and comprise steel or timber studs* on both faces with a minimum 1 layer of 13 mm thick boards, wall are required to be otherwise tested or assessed by other. Apertures are not required to be lined. Further, wall cavity insulation is optional.
 - b. Rigid walls: The wall must have a minimum thickness of 100 mm and comprise concrete, aerated concrete or masonry, with a minimum density of 650 kg/m³. Wall elements are required to be otherwise tested or assessed by others.
 - c. Rigid floors: The floor must have a minimum thickness of 100 mm and comprise aerated concrete or concrete with a minimum density of 650 kg/m³. Floor elements are required to be otherwise tested or assessed by others.

*no part of the penetration seal may be closer than 100 mm to a stud, the cavity must be closed between the penetration seal and the stud, and minimum 100 mm of insulation confirmed to be deemed non-combustible in accordance with AS 1530.1:1994 must be provided within the cavity between the penetration seal and the stud.

Wall and floor elements are required to be otherwise tested or assessed by others for the required fire resistance period. In cases where the FRL of the wall or floor is less than that of the penetration, the FRL will be derated accordingly.

Protecta Fire Protection Systems which involve services penetrating both sides of a flexible wall may also be used in the situation where the services penetrate one side of the wall only and the remaining side of the wall is not penetrated at the same point (i.e. the services continues on the inside of the wall). All fire integrity and insulation ratings for such single-sided penetrations remain the same as for the equivalent double-sided penetrations for all services except bare metallic pipes. For bare metallic pipes, the thermal insulation ratings will be required to be derated unless a 13 mm or 16 mm baffle system is installed on the unexposed side as per the application

3. Protecta EX Mortar may be used to provide a penetration seal with cables, cable trays, plastic pipes, composite pipes and metallic pipes with and without insulation, with mixed services in the same seal/aperture (for details see section 6.0).

Test results for the cables remain valid if the diameter of a single cable is reduced and/or the number of cables in a bunch is reduced provided that the overall diameter of the bunch of any individual cable is not greater than that tested.

The test results obtained with the standard configuration cover all types of insulated cables with copper or aluminium conductors, fibre optic cables and bundled communication cables, except hollow cables.

Results obtained from tests where the supports pass through the seal are applicable to those situations where the support is continued but not vice versa.

The test results obtained using standard configuration for cable penetration systems are valid for:

- a. All types of steel cable trays and ladders
 - b. Any penetration size equal or smaller than that tested, provided the total amount of cross sections of the cables (core and insulation) does not exceed 60% of the penetration.
4. In systems where insulation installed on metallic and composite pipes is interrupted, it has been established that the insulation doesn't contribute to the integrity rating of the system. Therefore, assuming insulation is zero, the integrity rating achieved must be maintained when such systems are used on uninsulated pipes.
 5. It was confirmed that where PP pipes are mentioned, this includes PP-MV, PP-H, PP-R and similar. Where PE pipes are mentioned, this includes PE-LD, PE-MD, PE-HD, PE-X and similar.
 6. Protecta EX Mortar may be used to seal apertures in the separating element up to 2400 mm wide by 1200 mm high in a wall, and 2400 mm by 1200 mm in a floor. The additional sizes that are permitted in floors are shown in Table 3.

Table 3 Variation to size

Width (mm)	Length (mm)
1100	2620
1000	2880
≤ 800	∞ (infinite)

The minimum permitted separation between adjacent seals/apertures is 200 mm. Services within the Protecta EX Mortar seal do not require a minimum separation, except where specifically detailed in section 6.0.

7. Support of services in walls and floors must be maintained as per AS 1530.4:2014 and AS 4072.1:2005 requirements.

Refer to section 6.0 for the assessed FRL given to each construction configuration.

4.2 Referenced test data

The assessment of the variation to the tested systems and the determination of the performance are based on the results of the fire tests documented in the reports summarised in Table 4. Further details of the tested systems are included in Appendix B.

Table 4 Referenced test data

Report number	Test sponsor	Test date	Testing authority	
WF 416697	Polyseam Ltd	14 August 2019	Warringtonfire, UK	
WF 394948		30 January 2018		
WF 405610		11 October 2018		
WF 405532 Revision A		8 October 2018		
WF 400805		8 November 2018		
WF 400806		25 October 2018		
WF 397686 Revision A		28 March 2018		
WF 392115		16 November 2017		
WF 19324A		31 October 2018		WFGENT, Belgium
WF 375797		9 March 2017		Warringtonfire, UK
WF 375799A	15 January 2016			
WF 375799B	23 March 2017			
WF 379319	2 February 2017			
WF 380963	6 March 2017			
WF 382337	19 April 2017			

4.3 Variations to the tested systems

The tested systems and variations to those tested systems – together with the referenced standard fire tests – are described in Table 5.

Table 5 Variations to tested systems

Item	Reference test	Description	Variations
1.	All tests listed in Table 4	The referenced tests were conducted in accordance with BS EN 1366-3:2009 ⁸ and BS EN 1363-1:2012 ⁹	Assess the systems in accordance with AS 1530.4:2014 and AS 4072.1:2005.
2.		The referenced tests were conducted to demonstrate how Protecta EX Mortar, a gypsum-based mortar material, is used to reinstate the fire resistance performance of flexible wall, rigid wall and floor constructions where they are penetrated by various cables, trays and metallic, plastic and composite pipes.	Assess the performance of various types and sizes of cables, metallic pipes, composite pipes and plastic pipes protected with Protecta EX Mortar and other supplementary fire sealing systems.
3.			Extension of FRLs to intermediate pipe sizes based on the testing of the maximum and minimum pipe size.
4.			<p>The separating elements are varied as follows:</p> <ul style="list-style-type: none"> + Increase in aperture size for fire seals filled with Protecta EX mortar + Test results from floors as applicable to walls. + The plasterboard wall partition assessed shall include the option of lining with two layers of minimum 13 mm thick fire grade plasterboard that has otherwise been tested or assessed as a wall to achieve a FRL - /120/120 on each side of steel or timber framed wall. + Applying test results obtained to masonry, AAC or concrete walls. + Wall thickness is reduced from 150 mm to 100 mm for section 6.3.5 and floor thickness is reduced from 150 mm as tested to 100 mm for assessed systems in sections 6.4.5 and 6.4.7. + The integrity rating achieved for insulated pipes can be applied to uninsulated pipes as shown in sections 6.3.3, 6.3.8, 6.4.2 and 6.4.6.

4.4 Test standard

AS 1530.4:2014 sets out procedures and methods for fire tests on building materials, components, structures, and fire-resistance tests for elements of construction. Section 10 discusses the procedures and methods for service penetrations and control joints.

4.5 Reference standard

AS 4072.1:2005 sets out the minimum requirements for the construction, installation and application of fire resistance tests to sealing systems around penetrations through separating building elements that are required to have an FRL.

⁸ European Committee for Standardization, 2009, Fire resistance tests for service installations. Penetration seals, BS EN 1366-3:2009, European Committee for Standardization, Brussels, Belgium.

⁹ European Committee for Standardization, 2012, Fire resistance tests – General requirements, BS EN 1363-1:2012, European Committee for Standardization, Brussels, Belgium.

5.0 Assessment 1 – Applicability of test results in accordance with AS 1530.4:2014

5.1 Description of variation

This assessment report is prepared based on referenced tests provided in Appendix B describing fire resistance testing of fire seals and service penetration protection in various fire separating elements, tested in accordance with BS EN 1363-1:2012, BS EN 1366:3 2009 and BS EN 1366-4:2006. These standards differ from AS 1530.4:2014. The effect these differences have on the fire resistance performance of the test specimens in accordance with AS 1530.4:2014 is discussed below.

5.2 Methodology

The method of assessment used is summarised in Table 6.

Table 6 Method of assessment

Assessment method	
Level of complexity	Complex assessment
NCC procedure for determining fire performance	Differs in only a minor degree from a tested prototype S1C2(b) and S1C2(c)
Type of assessment	Qualitative and comparative

5.3 Assessment

5.3.1 Specimen configuration

AS 1530.4:2014 clause 10.4.2 specifies that the service(s) shall be installed so that it projects a minimum 500 mm on each side of the supporting construction, of which at least 200 mm shall extend beyond the extremities of the penetration sealing system. The penetration sealing system shall include any coating, wrapping or other protections to the services. The length of unprotected service on the unexposed face shall not be greater than 500 mm. For plastic pipes, the external projection away from the furnace shall be increased to a minimum of 2000 mm. The measurements shall not include any part of the plug or cap used to seal a pipe within the furnace.

With respect to the pipe end configurations, AS 1530.4:2014 stipulates that services end conditions shall be representative of those intended to be used in practice.

The EN standard stipulates the following field of application based on the tested pipe end configuration:

Table 7 Field of application rules for pipe end configurations

		Tested			
		U/U	C/U	U/C	C/C
Covered	U/U	Y	N	N	N
	C/U	Y	Y	N	N
	U/C	Y	Y	Y	N
	C/C	Y	Y	Y	Y
Y=acceptable, N=not acceptable					

Based on the review of the test data and the above field of application, it is the opinion of this testing authority that services tested with an open/open (U/U) end fire configuration are considered to be the worst-case scenario as the hot gases will have a clear path to the unexposed side. As a result, the thermocouple placed on the service will likely record the highest temperature when compared to the rest of the pipe end configurations. Therefore, FRL achieved in U/U configuration can be extended to services tested in any of the pipe end configurations.

With respect to the services tested in an open/closed configuration or closed/closed configuration, it is considered that both configurations are not in line with the general requirement of the AS 1530.4:2014. However, AS 1530.4:2014 stipulates that "service end conditions shall be representative of those intended to be used in practice", therefore, it is reasonable to extend the FRL achieved in both configurations provided that they are representative of the system used in practice.

With respect to the difference in the pipe projection from the wall and the floor system, it is considered that this difference will not likely introduce any detrimental effect to the wall system as the plastic pipe is expected to melt in the first few minutes in a test, and once the sealant is activated, this difference can be negligible.

In case of a floor system, it is argued that having a 2000 mm projection out of the floor slab at the unexposed side may include a detrimental effect due to stack effect but it is also argued that 500 mm projection as stipulated in the BS EN standard could also be considered as the most onerous case as more hot gases are expected to pass from the exposed to the unexposed side at a faster rate, hence increasing the temperature recorded by the T/C placed on the service before the activation and closure of the fire rated sealant.

A 2000 mm pipe length on the unexposed side represents a slightly higher level of demand. Any short term heat sink effect exists only briefly before pipe softening and melting dominate behaviour. This influence is offset by the severity of the EN furnace curve during the early stages of exposure.

In conclusion, considerable amount of research and test history has showed that the extension of the pipe from the unexposed side will not likely have an impact on the performance of the plastic pipes, hence it can be positively assessed.

5.3.2 Furnace temperature measurements

The furnace thermocouples specified in AS 1530.4:2014 are type K, mineral insulated metal sheathed (MIMS), with a stainless-steel sheath having a wire of diameter of less than 1.0 mm and an overall diameter of 3 mm. The measuring junction protrudes at least 25 mm from the supporting heat resistant tube.

The furnace thermocouples specified in EN 1363-1:2012 are plate thermometers comprised of an assembly of a folded nickel alloy plate, a thermocouple fixed to it and insulation material. A thermocouple is fixed to the side of the plate facing the specimen, with the thermocouple hot junction protected by a pad of insulating material.

The plate is to be constructed from 150 ± 1 mm long by 100 ± 1 mm wide by 0.7 ± 0.1 mm thick austenitic nickel-based superalloy strips.

The measuring junction is to consist of nickel chromium/nickel aluminium (Type K) wire as defined in EN 60584-1, contained within mineral insulation in a heat-resisting steel alloy sheath of nominal diameter 1 mm to 3 mm, with the hot junctions electrically insulated from the sheath.

The thermocouple hot junction is to be fixed to the geometric centre of the plate in the position by a small steel strip made from the same material as the plate. The steel strip can be welded to the plate – or may be

screwed to it – to facilitate replacement of the thermocouple. The strip should be approximately 18 mm by 6 mm if it is spot-welded to the plate and nominally 25 mm by 6 mm if it is to be screwed to the plate. The screw is to be 2 mm in diameter.

The assembly of plate and thermocouple should be fitted with a pad of inorganic insulation material 97 ± 1 mm by 97 ± 1 mm by 10 ± 1 mm thick with a density of 280 ± 30 kg/m³.

EN 1363-1:2012 specifies that each plate thermometer shall be at least 100 ± 50 mm from the nearest point of the exposed face of the test construction, whereas AS 1530.4:2014 stipulates a distance of 100 ± 10 mm.

The furnace control thermocouples required by EN 1363-1:2012 are less responsive than those specified by AS 1530.4:2014. This variation in sensitivity can produce a potentially more onerous heating condition for specimens tested to EN 1363-1:2012, particularly when the furnace temperature is changing quickly in the early stages of the test. Furnace temperature regime

The furnace temperature regime for fire resistance tests conducted in accordance with AS 1530.4:2014 follows the same trend as EN1363-1:2012

The parameters outlining the accuracy of control of the furnace temperature in AS 1530.4:2014 and BS EN1363-1:2012 are not appreciably different.

5.3.3 Furnace pressure regime

It is a requirement of both AS 1530.4:2014 and EN 1363-1:2012 that for vertical elements, the furnace shall be operated so that the neutral pressure plane (a pressure of 0 Pa) is established at a height 500 mm above the notional floor level.

For wall penetrations, AS 1530.4:2014 requires that – if the separating element has a height greater than 1 m – it shall be tested with a pressure of 20 ± 3 Pa at the top of the separating element and that the horizontal penetrating services shall be included in the zone where positive pressure exceeds 10 Pa. EN 1366-3:2009 specifies that a minimum pressure of 20 Pa shall be maintained at the top of the uppermost penetration seal in a vertical supporting construction and that services shall only be included in the zone where the positive pressure exceeds 10 Pa.

Therefore, both standards require that a minimum pressure of 10 Pa be maintained at the lowest point of the lowest service.

It is a requirement of both AS 1530.4:2014 and EN 1363-1:2012 that for horizontal elements, a furnace gauge pressure of 20 Pa is established at a height 100 mm below the floor soffit level.

The parameters outlining the accuracy of control of the furnace pressure in AS 1530.4:2014 and EN 1363.1-:2012 are also not appreciably different.

5.3.4 Integrity performance criteria

In accordance with AS 1530.4:2014, while a specimen maintains its insulation performance, the specimen shall be deemed to have failed the integrity criterion if it collapses or sustains flaming on the unexposed face, which can ignite a cotton pad when applied for up to 30 seconds.

A specimen shall be deemed to have failed the integrity criterion in accordance with AS 1530.4:2014 when any of the following occur:

- + Sustained flaming for 10 seconds.

- + A gap forms that allows the passage of hot gases to the unexposed face and ignites the cotton pad when applied for up to 30 seconds.
- + A gap forms that allows the penetration of a 25 mm gap gauge anywhere on the specimen.
- + A gap forms that allows a 6 mm × 150 mm gap gauge to penetrate the specimen anywhere on the specimen.

Except for minor variations the integrity criteria in EN 1363.1:1999 are generally applied in a comparable manner. The integrity criteria differ slightly between AS 1530.4:2014 and BS EN 1363-1:2012.

5.3.5 Specimen temperature measurement

The specimen thermocouple specification of service penetrations is generally the same for AS 1530.4:2014 and BS EN 1366-3:2009.

For the penetration construction considered. AS 1530.4:2014 specifies the following locations for thermocouples to be placed.

- + At not less than two points approximately 25 mm from the edge of the hole made for the passage of the service (one in uppermost vertical plane).
- + On the surface of the penetrating service, at least two thermocouples located approximately 25 mm from the plane of the general surface of the penetrated element (one in uppermost vertical plane).
- + At least two positions 25 mm from the interface of the separating element and main penetration seal.

For penetrating sealing systems, BS EN 1363-1:2012 specifies thermocouples are fixed in generally similar locations on the unexposed face: on the supporting construction and/or seal and on the penetrating service adjacent at the plane of penetration, and on the penetrating service some distance from the plane of penetration.

Based on the above, the effect of the differences on the thermocouple locations of the tested construction and the specifications in AS 1530.4:2014 discussed on case-by-case basis.

5.3.6 Insulation performance criteria

The general insulation criteria of AS 1530.4:2014 and BS EN 1363.1:2012 are not appreciably different.

5.4 Application of test data to AS 1530.4:2014

The variations in furnace heating regimes, furnace thermocouples and the responses of the different thermocouples types to the furnace conditions are not expected to have a significant effect on the outcome of the referenced fire resistance test.

In the referenced tests, some specimens were not in accordance with AS 1530.4:2014, especially the capping arrangement of pipes. Those services were included in the assessment with the same end conditions as tested.

Based on the above discussion, it is considered that the results relating to the integrity and insulation performance of the referenced tests can be used as a basis to assess the FRL of the specimens in accordance with AS 1530.4:2014.

6.0 Assessment 2 – Fire resistance performance of services protected with Protecta EX Mortar

6.1 Description of variation

Various service penetrations, including metal pipes, plastic pipes and cables are tested protected with Protecta EX Mortar applied at around the pipe to various depths at the aperture of the separating element. Other local protection systems such as Protecta FR Wrap have also been tested in combination with Protecta EX Mortar.

6.2 Methodology

The method of assessment used is summarised in Table 8.

Table 8 Method of assessment

Assessment method	
Level of complexity	Complex assessment
NCC procedure for determining fire performance	Differs in only a minor degree from a tested prototype S1C2(b) and S1C2(c)
Type of assessment	Qualitative and comparative

6.3 Rigid wall constructions according to section 4.1 dot point 2 with wall thickness of minimum 150 mm

6.3.1 Cable penetration seal with 50 mm deep Protecta EX Mortar backed with mineral fibre board

Table 9 Construction details

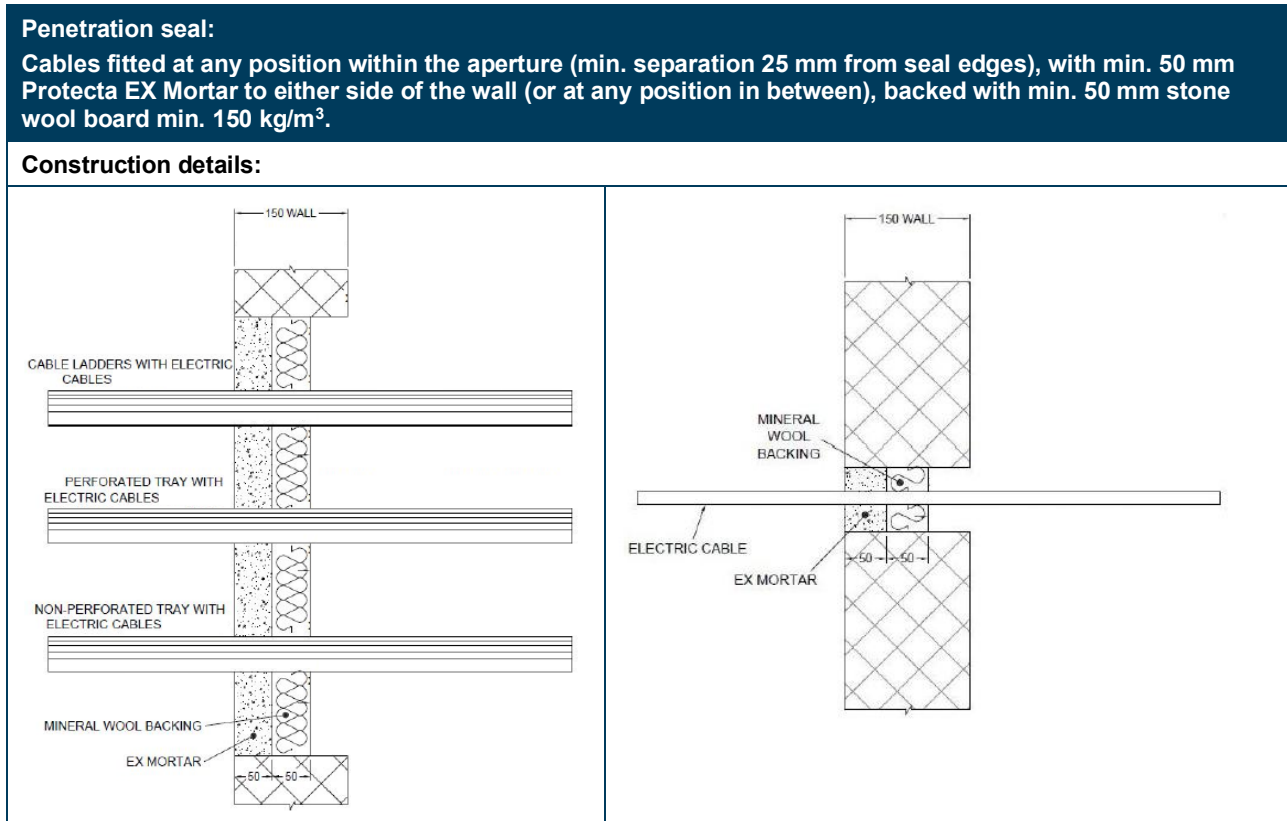

Table 10 Single side penetration seal with cables

Services	Maximum aperture	FRL
None (blank)	As section 4.1 dot point 4	-/180/120
Single electrical cables up to Ø 21 mm		-/180/60
Single electrical cables up to Ø 21 mm	80 mm x 80 mm	-/240/60
Electrical cables up to Ø 21 mm (single, bundled and on trays)	As section 4.1 dot point 4	-/180/60
Electrical cables up to Ø 50 mm (single, bundled and on trays)		-/180/45
Electrical cables up to Ø 80 mm (single, bundled and on trays)		-/120/45
Telecommunication cables up to Ø 21 mm (single or bundles up to Ø 100 mm)		-/180/90
Steel cable trays & ladders		-/180/60
Non-sheathed wires up to Ø 17 mm		-/180/45
Non-sheathed wires up to Ø 24 mm		-/180/30
Copper conduit up to Ø 16 mm		-/180/30
Steel conduit up to Ø 16 mm		-/180/60
PVC conduit up to Ø 16 mm		-/180/60

6.3.2 Pipe penetration seal with 50 mm deep Protecta EX Mortar backed with mineral fibre board

Table 11 Construction details

<p>Penetration seal: CS (Continuous Sustained) insulated metallic pipes fitted at any position within the aperture (min. separation 30 mm from seal edges, with min. 50 mm Protecta EX Mortar to either sides of the wall (or any position in between), backed with min. 50 mm stone wool min. 150 kg/m³.</p>	
<p>Construction details:</p>	
<p>Configuration 1</p>	<p>Configuration 2</p>
<p>Key: 1 Supporting construction a1 Pipe / top edge of seal separation a2 Pipe / side edge of seal separation a3 Pipe / pipe separation</p>	

Table 12 Single side penetration seal with pipes

Services	Maximum aperture	Insulation	FRL
Steel pipes 219 diameter/ 5-14.2 mm wall	As section 4.1 dot point 4	30 mm stone wool min. 80 kg/m ³	-/120/90 C/U

6.3.3 Pipe penetration seal with 50 mm deep Protecta EX Mortar backed with mineral fibre board

Table 13 Construction details

<p>Penetration seal: LI (Local Interrupted) or CI (Continuous Interrupted) insulated metallic and composite pipes fitted at any position within the aperture (min. separation 30 mm from seal edges, with min. 50 mm Protecta EX Mortar to either sides of the wall (or any position in between), backed with min. 50 mm stone wool min. 150 kg/m³.</p>	
<p>Construction details:</p>	
<p>Configuration 1</p>	<p>Configuration 2</p>
<p>Key: 1 Supporting construction a1 Pipe / top edge of seal separation a2 Pipe / side edge of seal separation a3 Pipe / pipe separation</p>	

Table 14 Single side penetration seal with pipes

Services	Maximum aperture	Insulation, minimum length, thickness and density	FRL
Copper or steel pipes up to 12 mm diameter/ 0.9-5 mm wall	70 mm × 70 mm	1000 mm long, 20 mm stone wool 80 kg/m ³	-/240/240 C/C
Copper or steel pipes up to 54 mm diameter/ 1-14.2 mm wall	115 mm × 115 mm	1000 mm long, 20 mm stone wool 80 kg/m ³	-/240/120 C/C
Copper or steel pipes up to 54 mm diameter/ 1-14.2 mm wall	As section 4.1 dot point 4	1000 mm long, 20 mm stone wool 80 kg/m ³	-/180/120 C/C

Services	Maximum aperture	Insulation, minimum length, thickness and density	FRL
75 mm Alupex composite pipes with 7.5 mm wall		600 mm long, 32 mm Elastomeric insulation minimum class B-s3,d0	-/60/60 C/C

Table 15 Single side penetration seal with pipes

Services	Maximum aperture	Insulation	FRL	
Mild or stainless steel pipe				
40 mm diameter/1.5-14.2 mm wall*	100 mm x 100 mm	1000 mm long, 20 mm stone wool 80 kg/m ³	-/240/240 C/U	
40 mm diameter/1.5-14.2 mm wall*	As section 4.1 dot point 4		1000 mm long, 30 mm stone wool 80 kg/m ³	-/180/120 C/U
40 mm diameter/1.5-14.2 mm wall*				
50 mm diameter/1.7-14.2 mm wall*				
60 mm diameter/1.9-14.2 mm wall*				
75 mm diameter/2.2-14.2 mm wall*				
90 mm diameter/2.5-14.2 mm wall*				
100 mm diameter/2.7-14.2 mm wall*				
115 mm diameter/3.0-14.2 mm wall*				
140 mm diameter/3.5-14.2 mm wall*				
165 mm diameter/3.9-14.2 mm wall*				
180 mm diameter/4.2-14.2 mm wall*				
200 mm diameter/4.6-14.2 mm wall*				
219 mm diameter/5.0-14.2 mm wall*				
Note: *Typical pipe diameters shown, see below graph in Figure 1 for intermediate sizes				

Pipe diameter vs Wall thickness

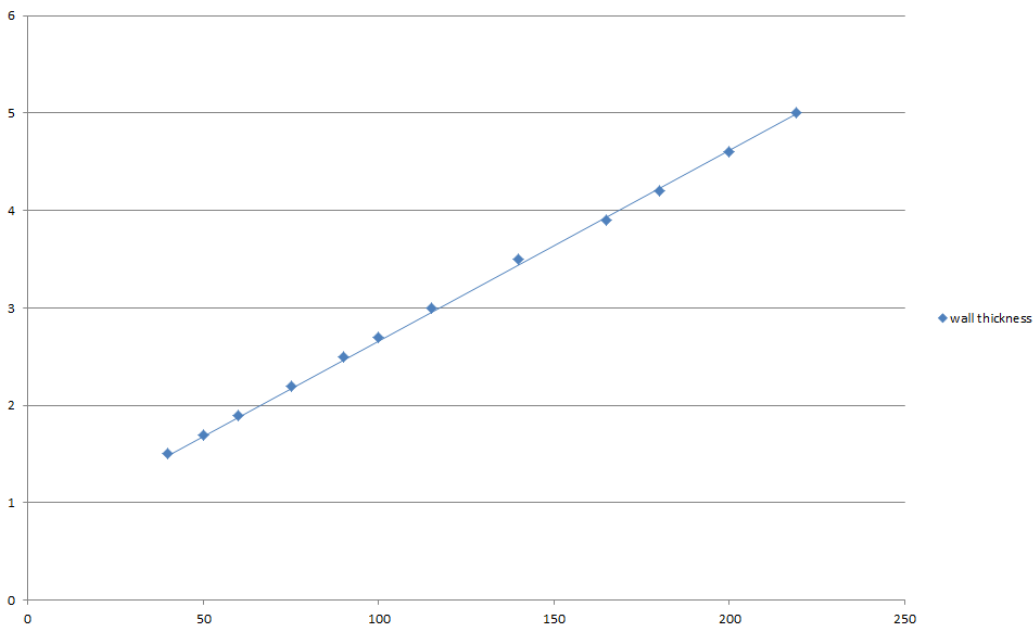

Figure 1 Intermediate pipe wall thicknesses for typical mild or stainless steel pipe diameters

6.3.4 Cable penetration seal with 100 mm deep Protecta EX Mortar

Table 16 Construction details

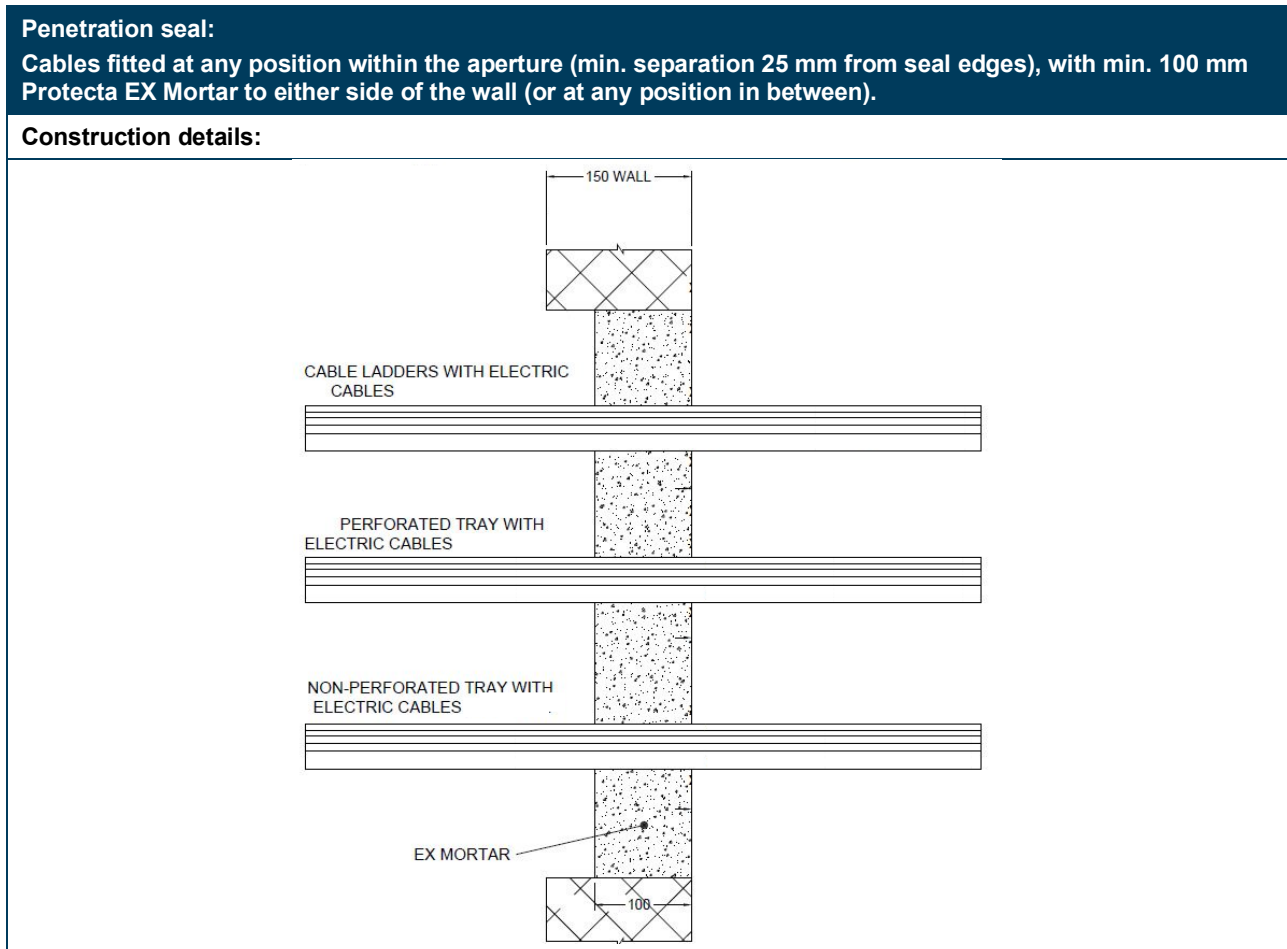

Table 17 Single side penetration seal with cables

Services	Maximum aperture	FRL
None (blank)	As section 4.1 dot point 4	-/240/240
Electrical cables up to Ø 21 mm (single, bundled an on trays)		-/240/60
Electrical cables up to Ø 80 mm (single, bundled an on trays)		
Cables up to Ø 21 mm in tied bundles up to Ø 100 mm Ø		-/120/120
Steel cable trays & ladders		-/120/60
Non-sheathed cables up to Ø 24 mm Ø		
Copper conduit up to Ø 16 mm		-/180/30 C/U
Steel conduit up to Ø 16 mm		-/180/60 C/U
PVC conduit up to Ø 16 mm		-/240/240 C/C

6.3.5 Pipe penetration seal with 100 mm deep Protecta EX Mortar

Table 18 Construction details

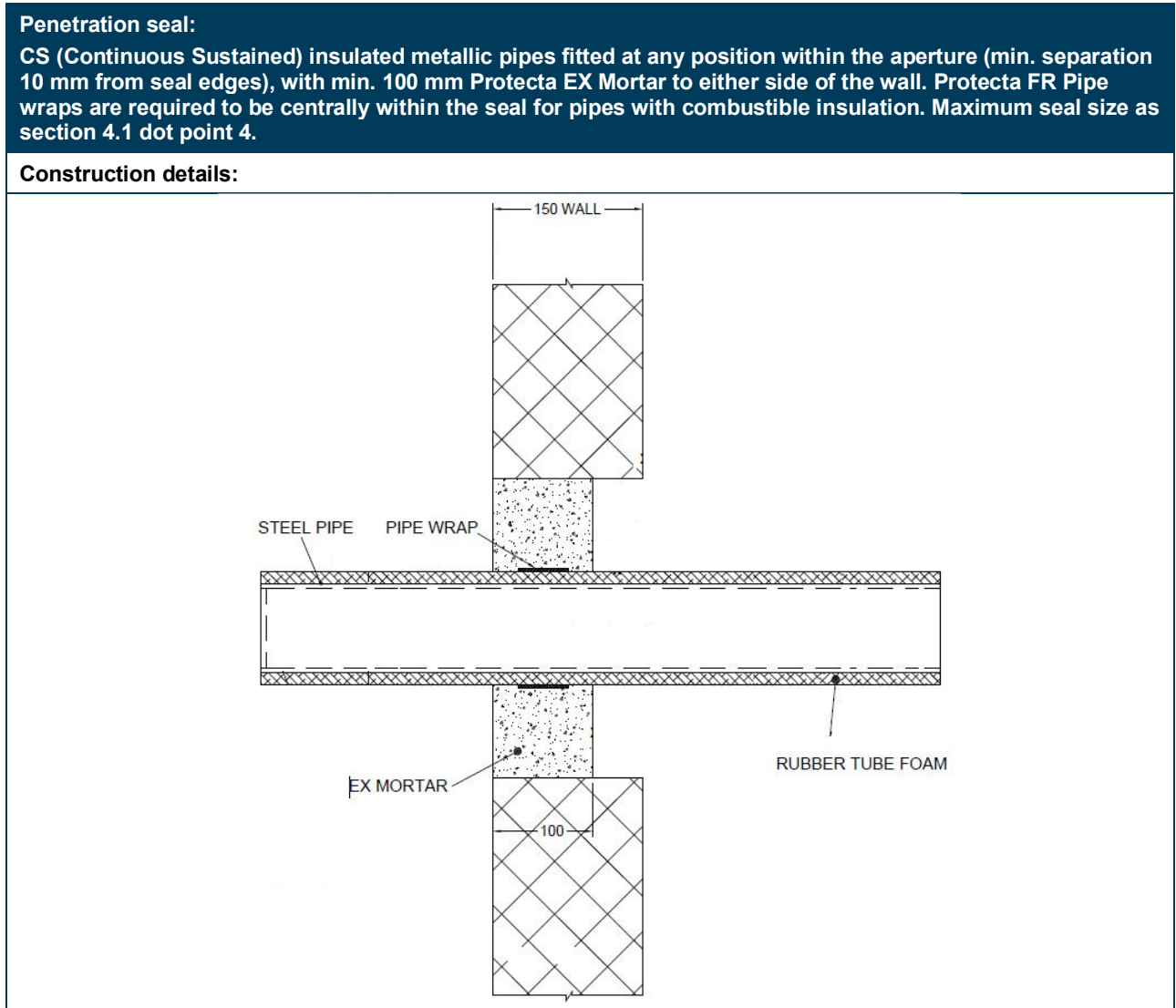

Table 19 Single side penetration seal with pipes

Services	Wrap	Insulation	FRL
Mild or stainless steel pipe			
40 mm diameter/ 1.5-14.2 mm wall	1 off 50 mm x 3.6 mm Protecta FR Pipe Wrap, fitted central	13 mm Elastomeric insulation minimum class B-s3, d0	-/240/240 C/U
165 mm diameter/4.5-14.2 mm wall		9 mm Elastomeric insulation minimum class B-s3, d0	-/240/30 C/U
40 mm diameter/1.5-14.2 mm wall*	1 off 50 mm x 1.8mm Protecta FR Pipe Wrap, fitted central	13-19mm Elastomeric insulation minimum class B-s3, d0	-/240/60 C/U
50 mm diameter/1.5-14.2 mm wall*			
60 mm diameter/1.5-14.2 mm wall*			
75 mm diameter/1.5-14.2 mm wall*			

Services	Wrap	Insulation	FRL
90 mm diameter/1.5-14.2 mm wall*			
100 mm diameter/1.5-14.2 mm wall*			
115 mm diameter/2.3-14.2 mm wall*			
140 mm diameter/2.6-14.2 mm wall*			
165 mm diameter/2.8-14.2 mm wall*			
Note: *Typical pipe diameters shown, see graph in Figure 2 for intermediate sizes			

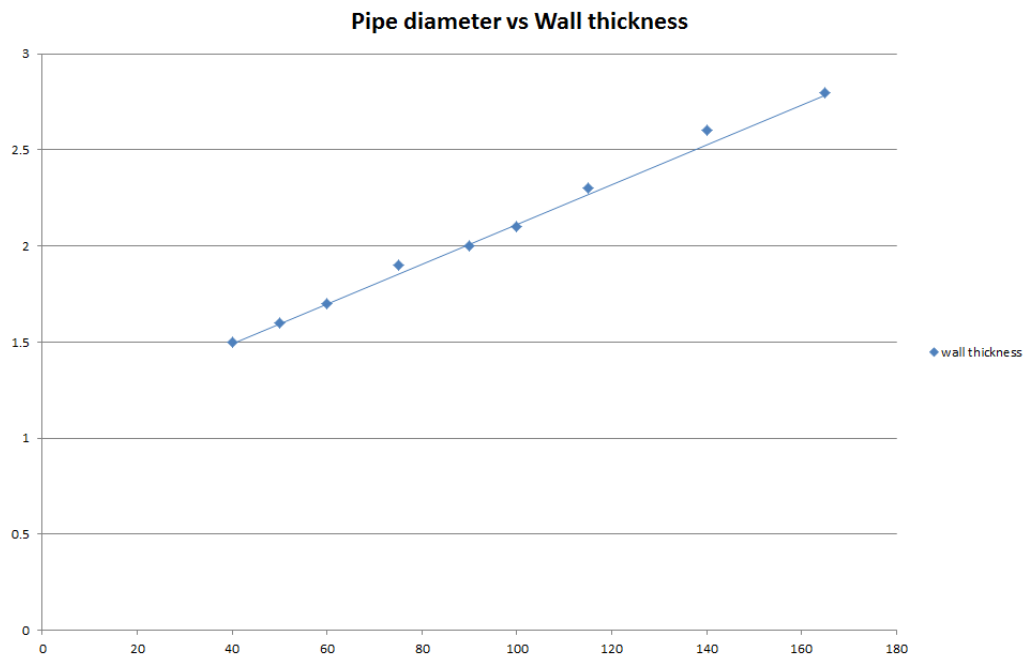

Figure 2 Intermediate pipe wall thicknesses for typical mild or stainless steel pipe diameters

Table 20 Single side penetration seal with pipes

Services	Wrap	Insulation	FRL
Mild or stainless steel pipe			
40 mm diameter/1.5-14.2 mm wall*	1 off 50 mm × 3.6 mm Protecta FR Pipe Wrap, fitted central	13-25 mm Elastomeric insulation minimum class B-s3, d0	-/180/60 C/U
50 mm diameter/1.8-14.2 mm wall*			
60 mm diameter/2-14.2 mm wall*			
75 mm diameter/2.3-14.2 mm wall*			
90 mm diameter/2.7-14.2 mm wall*			
100 mm diameter/2.9-14.2 mm wall*			
115 mm diameter/3.3-14.2 mm wall*			
140 mm diameter/3.9-14.2 mm wall*			
165 mm diameter/4.5-14.2 mm wall*			
Note: *Typical pipe diameters shown, see below graph in Figure 3 for intermediate sizes			

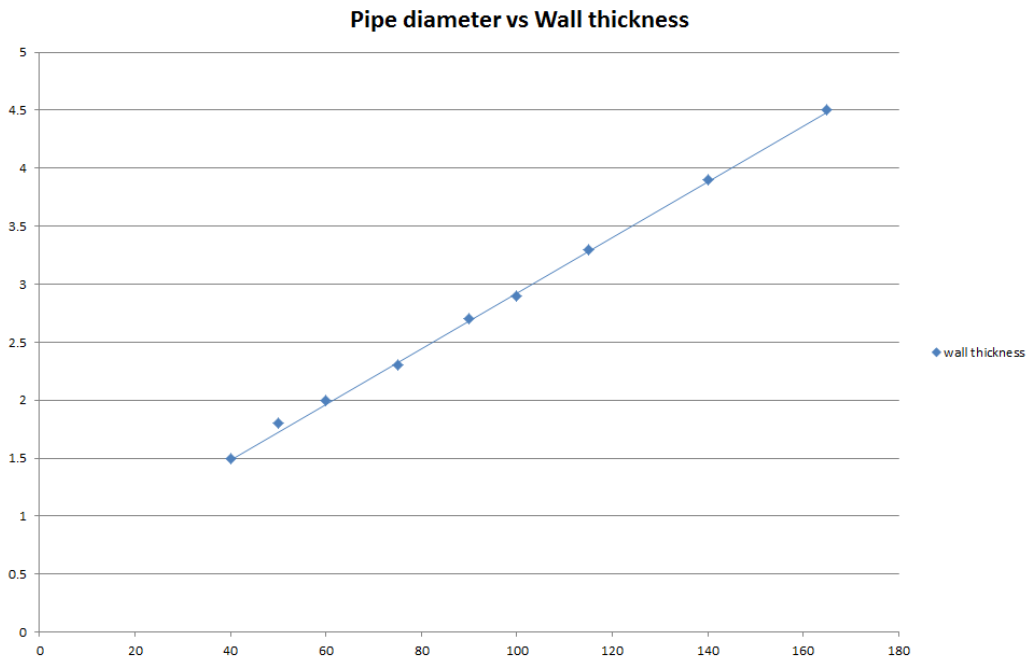

Figure 3 Intermediate pipe wall thicknesses for typical mild or stainless steel pipe diameters

6.3.6 Pipe penetration seal with 100 mm deep Protecta EX Mortar

Table 21 Construction details

Penetration seal:
 Plastic pipes fitted at any position within the aperture (min. separation 10 mm from seal edges), with min. 100 mm Protecta EX Mortar to either side of the wall. Protecta FR Pipe wraps are required to be centrally within the seal. Maximum seal size as section 4.1 dot point 4.

Construction details:

Table 22 Single side penetration seal with pipes

Services	Wrap	Insulation	FRL
PVC-U pipes			
315 mm diameter/9.2 mm wall	1 off 75 mm × 18 mm Protecta FR Pipe Wrap, fitted central	None	-/120/120 C/C

6.3.7 Pipe penetration seal with 100 mm deep Protecta EX Mortar

Table 23 Construction details

<p>Penetration seal: Combustible pipes sealed with Protecta EX Mortar, to either side of the wall. Minimum separation between pipes of 30 mm (a3) and from seal edges 30 mm (a1 & a2). Maximum seal size as section 4.1 dot point 4.</p>	
<p>Construction details:</p>	
<p>Configuration 1</p>	<p>Configuration 2</p>
<p>Key: 1 Supporting construction a1 Pipe / top edge of seal separation a2 Pipe / side edge of seal separation a3 Pipe / pipe separation</p>	

Table 24 Single side penetration seal with pipes

Services	Seal depth, minimum	Permitted configuration for seal separation	FRL
PVC-U pipes			
Diameter up to 32 mm, wall thickness 1.6 – 2.4 mm	100 mm	1 & 2	-/120/120 U/C C/C
PE pipes			
Diameter up to 32 mm, wall thickness 1.8 – 3.0 mm	100 mm	1 & 2	-/120/120 U/C C/C
PP pipes			
Diameter up to 32 mm, wall thickness 1.9 – 4.4 mm	100 mm	1 & 2	-/120/120 U/C C/C

6.3.8 Pipe penetration seal with 100 mm deep Protecta EX Mortar

Table 25 Construction details

Penetration seal: 1000 mm (min.) LI (Local Interrupted) or CI (Continuous Interrupted) insulated metallic pipes fitted at any position within the aperture (min. separation 20 mm from seal edges, with min. 100 mm Protecta EX Mortar to either sides of the wall (or any position in between)).	
Construction details:	
Configuration 1	Configuration 2
Key: 1 Supporting construction a1 Pipe / top edge of seal separation a2 Pipe / side edge of seal separation a3 Pipe / pipe separation	

Table 26 Single side penetration seal with pipes

Services	Maximum aperture	Insulation	FRL
Mild or stainless steel pipes			
40 mm diameter/1.5-14.2 mm wall*	As section 4.1 dot point 4	20 mm Stone wool insulation 80 kg/m ³	-/240/240 C/U
40 mm diameter/1.5-14.2 mm wall*		30 mm Stone wool insulation 80 kg/m ³	-/240/120 C/U
50 mm diameter/1.7-14.2 mm wall*			
60 mm diameter/1.9-14.2 mm wall*			
75 mm diameter/2.2-14.2 mm wall*			
90 mm diameter/2.5-14.2 mm wall*			
100 mm diameter/2.7-14.2 mm wall*			
115 mm diameter/3-14.2 mm wall*			
140 mm diameter/3.5-14.2 mm wall*			
165 mm diameter/3.9-14.2 mm wall*			
180 mm diameter/4.2-14.2 mm wall*			
200 mm diameter/4.6-14.2 mm wall*			
219 mm diameter/5.0-14.2 mm wall*			
Note: *Typical pipe diameters shown, see below graph in Figure 4 for intermediate sizes			

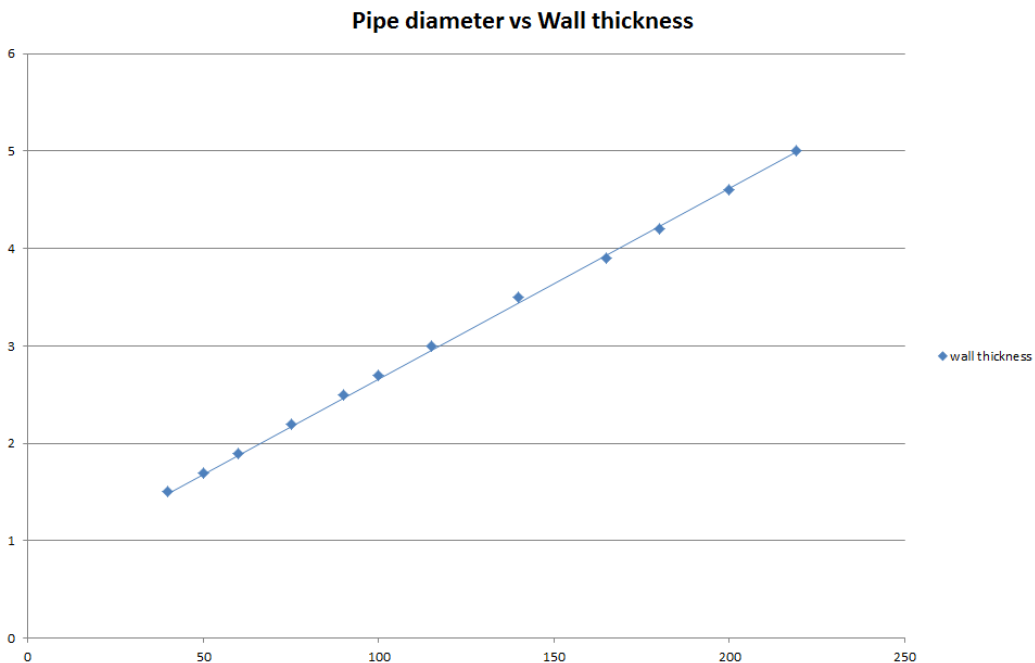

Figure 4 Intermediate pipe wall thicknesses for typical mild or stainless steel pipe diameters

6.3.9 Pipe penetration seal with 50 mm deep Protecta EX Mortar to both faces

Table 27 Construction details

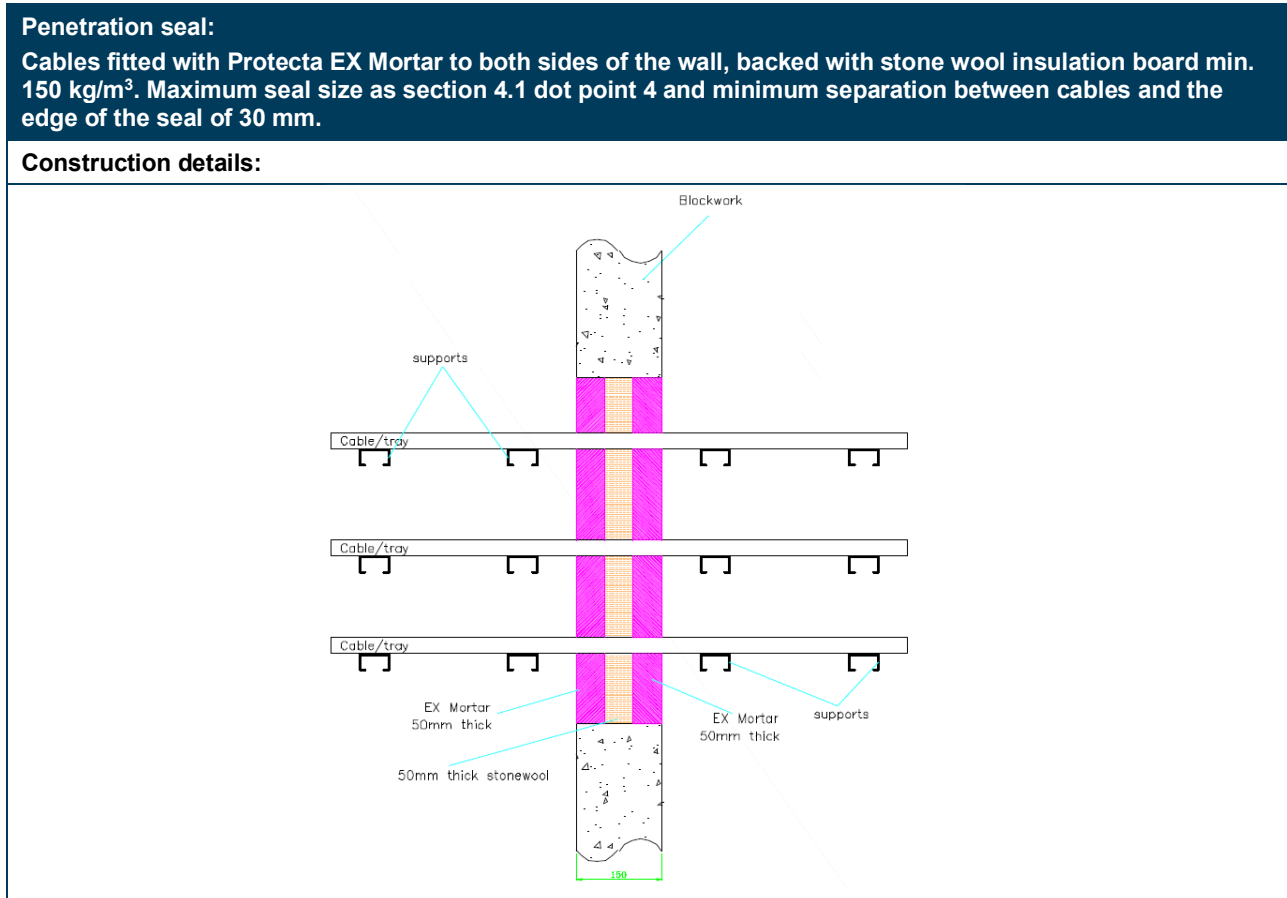

Table 28 Single side penetration seal with pipes

Services	Mortar Depth	Backing	Insulation	FRL
Blank seals	Minimum 50 mm	Minimum 50 mm Stone wool 150 kg/m ³	None	-/240/240
Electric cables up to 80 mm diameter, single or in a bundle				-/240/60
Steel cable trays and ladders up to 500 mm wide				
Telecoms cables up to 21 mm diameter, single or in a bundle up to 100 mm diameter				-/60/60
Unsheathed wire up to 24 mm diameter				-/240/120

6.4 Rigid floor constructions according to 4.1 dot point 2 with floor thickness of minimum 100 mm

6.4.1 Cable penetration seal with 50 mm deep Protecta EX Mortar backed with mineral fibre board

Table 29 Construction details

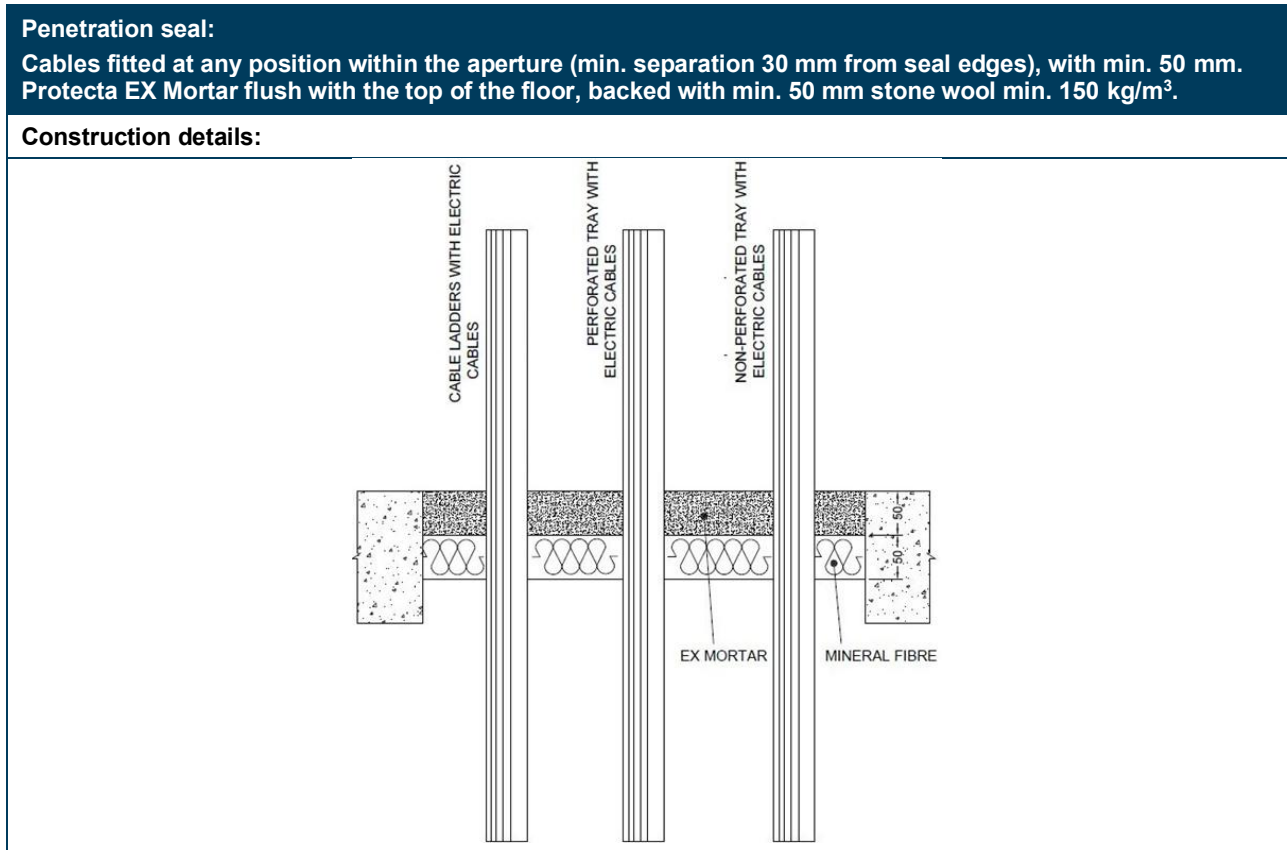

Table 30 Single side penetration seal with cables

Services	Maximum aperture	FRL
None (blank)	As section 4.1 dot point 4	-/180/180
Single* electrical cables up to Ø 21 mm		-/180/90
Electrical cables up to Ø 21 mm (single, bundled and on trays)		-/180/60
Electrical cables up to 80 mm (single, bundled and on trays)		-/90/45
Cables up to Ø 21 mm in tied bundles up to Ø 100 mm		-/180/180
Steel cable trays & ladders		-/90/60
Non-sheathed wires up to Ø 17 mm		-/180/60
Non-sheathed wires up to Ø 24 mm		-/180/30
PVC conduits up to Ø 16 mm		-/180/180 C/U, C/C
Note *To be separated by at least 30 mm		

6.4.2 Pipe penetration seal with 50 mm deep Protecta EX Mortar backed with mineral fibre board

Table 31 Construction details

<p>Penetration seal: 1000 mm (min.) LI (Local Interrupted) or CI (Continuous Interrupted) insulated metallic pipes fitted at any position within the aperture (min. separation 30 mm from seal edges, with min. 50 mm Protecta EX Mortar flush with the top of floor, backed with min. 50 mm stone wool min. 150 kg/m³.</p>	
<p>Construction details:</p> <div style="text-align: center;"> </div>	
<p>Configuration 1</p> <div style="text-align: center;"> </div>	<p>Configuration 2</p> <div style="text-align: center;"> </div>
<p>Key: 1 Supporting construction a1 Pipe / top edge of seal separation a2 Pipe / side edge of seal separation a3 Pipe / pipe separation</p>	

Table 32 Single side penetration seal with pipes

Services	Maximum aperture	Insulation, minimum thickness and density	FRL
Copper or steel pipes up to 12 mm diameter/ 1-5 mm wall	70 mm × 70 mm	20 mm stone wool 80 kg/m ³	-/240/240 C/C
Copper or steel pipes up to 54 mm diameter/ 1-14.2 mm wall	115 mm × 115 mm		-/240/180 C/C
Copper or steel pipes up to 54 mm diameter/1-14.2 mm wall	As section 4.1 dot point 4		-/180/180 C/C

Table 33 Single side penetration seal with pipes

Services	Maximum aperture	Insulation, minimum thickness and density	FRL
Mild or stainless steel pipes			
40 mm diameter/1-14.2 mm wall*	280 mm × 280 mm	20 mm Stone wool insulation 80 kg/m ³	-/240/240 C/U
40 mm diameter/1-14.2 mm wall*		30 mm Stone wool insulation 80 kg/m ³	-/240/90 C/U
50 mm diameter/1.2-14.2 mm wall*			
60 mm diameter/1.4-14.2 mm wall*			
75 mm diameter/1.7-14.2 mm wall*			
90 mm diameter/2-14.2 mm wall*			
100 mm diameter/2.2-14.2 mm wall*			
115 mm diameter/2.5-14.2 mm wall*			
140 mm diameter/3-14.2 mm wall*			
165 mm diameter/3.5-14.2 mm wall*			
180 mm diameter/3.8-14.2 mm wall*			
200 mm diameter/4.2-14.2 mm wall*			
219 mm diameter/4.5-14.2 mm wall*			

Note:

*Typical pipe diameters shown, see below graph in Figure 5 for intermediate sizes

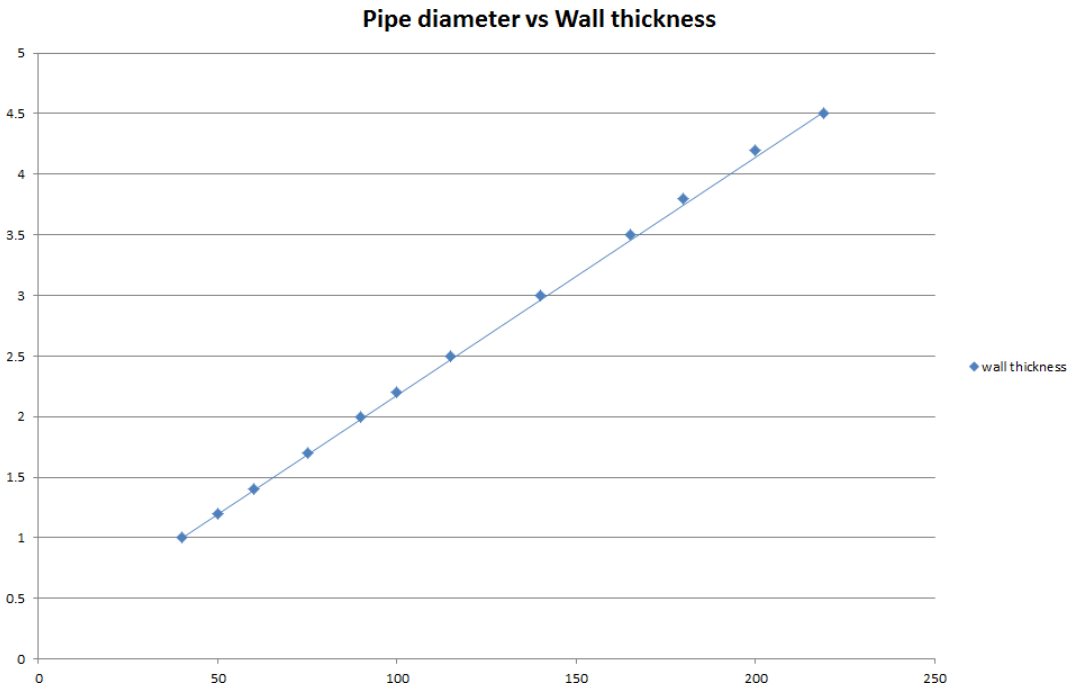

Figure 5 Intermediate pipe wall thicknesses for typical mild or stainless steel pipe diameters

Table 34 Single side penetration seal with pipes

Services	Maximum aperture	Insulation, minimum thickness and density	FRL
Mild or stainless steel pipes			
40 mm diameter/1-14.2 mm wall*	As section 4.1 dot point 4	20 mm Stone wool insulation 80 kg/m ³	-/180/180 C/U
40 mm diameter/1-14.2 mm wall*		30 mm Stone wool insulation 80 kg/m ³	-/180/90 C/U
50 mm diameter/1.2-14.2 mm wall*			
60 mm diameter/1.4-14.2 mm wall*			
75 mm diameter/1.7-14.2 mm wall*			
90 mm diameter/2-14.2 mm wall*			
100 mm diameter/2.2-14.2 mm wall*			
115 mm diameter/2.5-14.2 mm wall*			
140 mm diameter/3-14.2 mm wall*			
165 mm diameter/3.5-14.2 mm wall*			
180 mm diameter/3.8-14.2 mm wall*			
200 mm diameter/4.2-14.2 mm wall*			
219 mm diameter/4.5-14.2 mm wall*			
Note: *Typical pipe diameters shown, see below graph in Figure 6 for intermediate sizes			

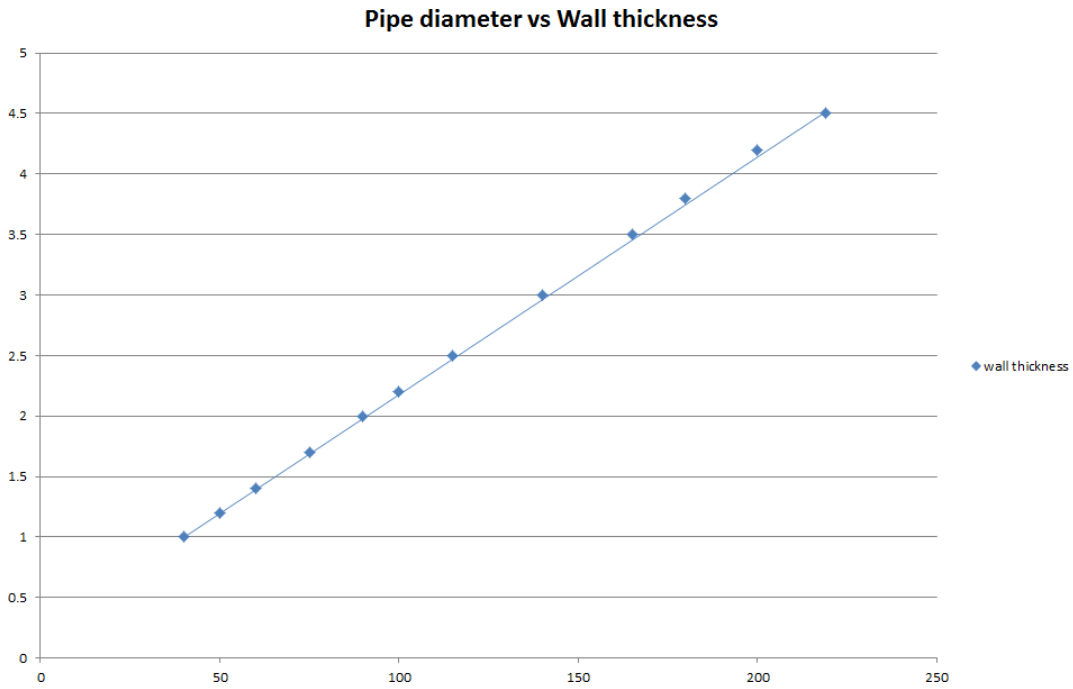

Figure 6 Intermediate pipe wall thicknesses for typical mild or stainless steel pipe diameters

6.4.3 Pipe penetration seal with 50 mm deep Protecta EX Mortar backed with mineral fibre board

Table 35 Construction details

<p>Penetration seal: CS (Continuous Sustained) insulated metallic pipes fitted at any position within the aperture, with min. 50 mm Protecta EX Mortar, backed with min. 50 mm stone wool min. 150 kg/m³ positioned at any height within the depth of the floor. Minimum separation between penetration seals and seal edges of 30 mm (configuration 1 & 2). Maximum aperture size as 4.1 dot point 4.</p>	
<p>Construction details:</p> 	
<p>Configuration 1</p> 	<p>Configuration 2</p> 
<p>Key: 1 Supporting construction a1 Pipe / top edge of seal separation a2 Pipe / side edge of seal separation a3 Pipe / pipe separation</p>	

Table 36 Pipe penetration seal with 50 mm deep Protecta EX Mortar backed with mineral fibre board

Services	Insulation	FRL
Mild or stainless steel pipes		
40 mm diameter/1-14.2 mm wall	20 mm thick stone, mineral wool minimum 80 kg/m ³	-/180/180 C/U (-240/240 C/U)*
40 mm diameter/1-14.2 mm wall*	30-80 mm thick stone, mineral wool minimum 80 kg/m ³	
50 mm diameter/1.2-14.2 mm wall*		
60 mm diameter/1.4-14.2 mm wall*		
75 mm diameter/1.6-14.2 mm wall*		
90 mm diameter/1.9-14.2 mm wall*		
100 mm diameter/2.1-14.2 mm wall*		
115 mm diameter/2.4-14.2 mm wall*		
140 mm diameter/2.9-14.2 mm wall*		
165 mm diameter/ 3.4-14.2 mm wall*		
180 mm diameter/ 3.6-14.2 mm wall*		
200 mm diameter/ 4.0-14.2 mm wall*		
219 mm diameter/ 4.3-14.2 mm wall*		
250 mm diameter/ 5.0-14.2 mm wall*		
300 mm diameter/ 5.9-14.2 mm wall*		
324 mm diameter/ 6.35-14.2 mm wall*		
PEX pipe in pipe systems		
15 mm diameter × 2.5 mm wall inner /25 mm diameter outer	None	-/180/180 C/C (-240/240 C/C)*
Note: */-240/240 in apertures up to a maximum of 550 mm × 1100 mm		

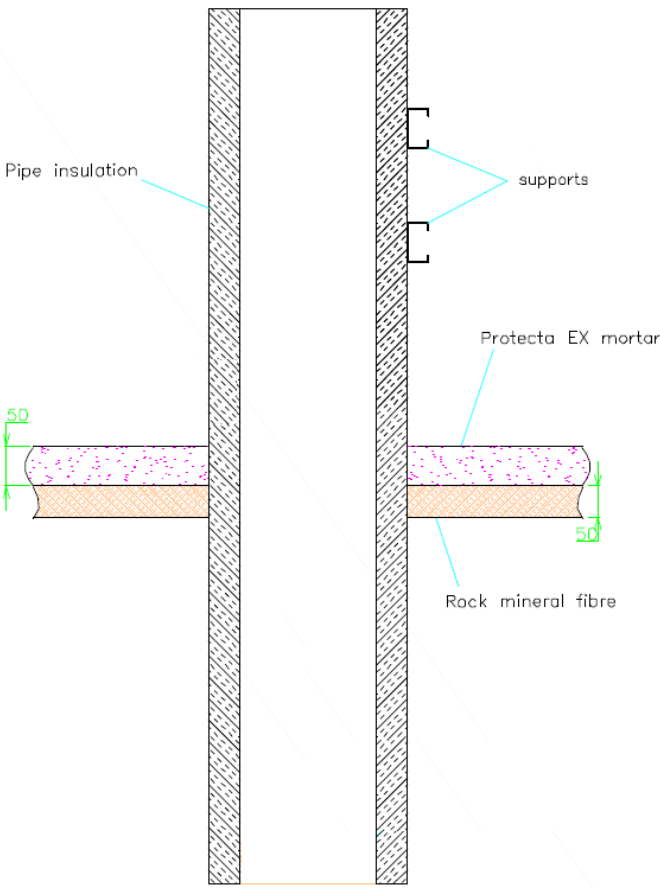
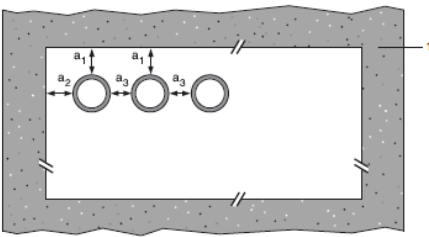
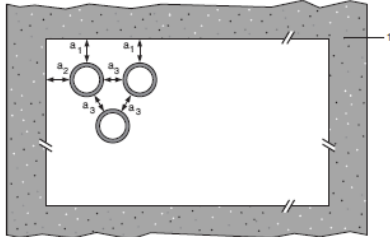
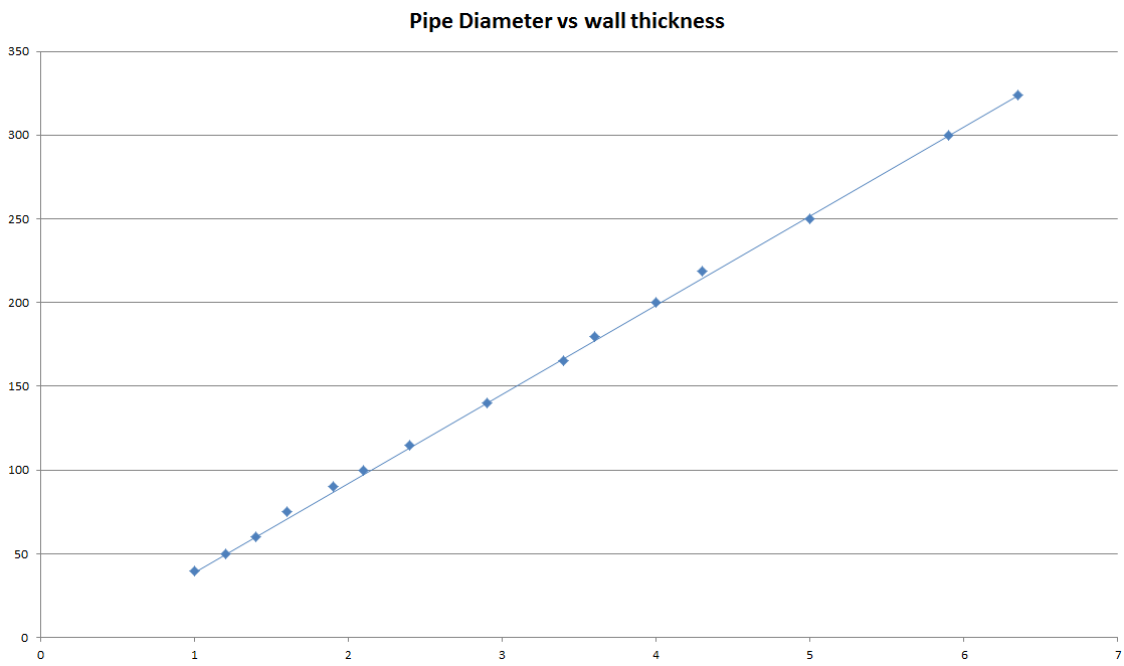

Figure 7 Intermediate pipe wall thicknesses for typical mild or stainless steel pipe diameters

6.4.4 Cable penetration seal with 100 mm deep Protecta EX Mortar

Table 37 Construction details

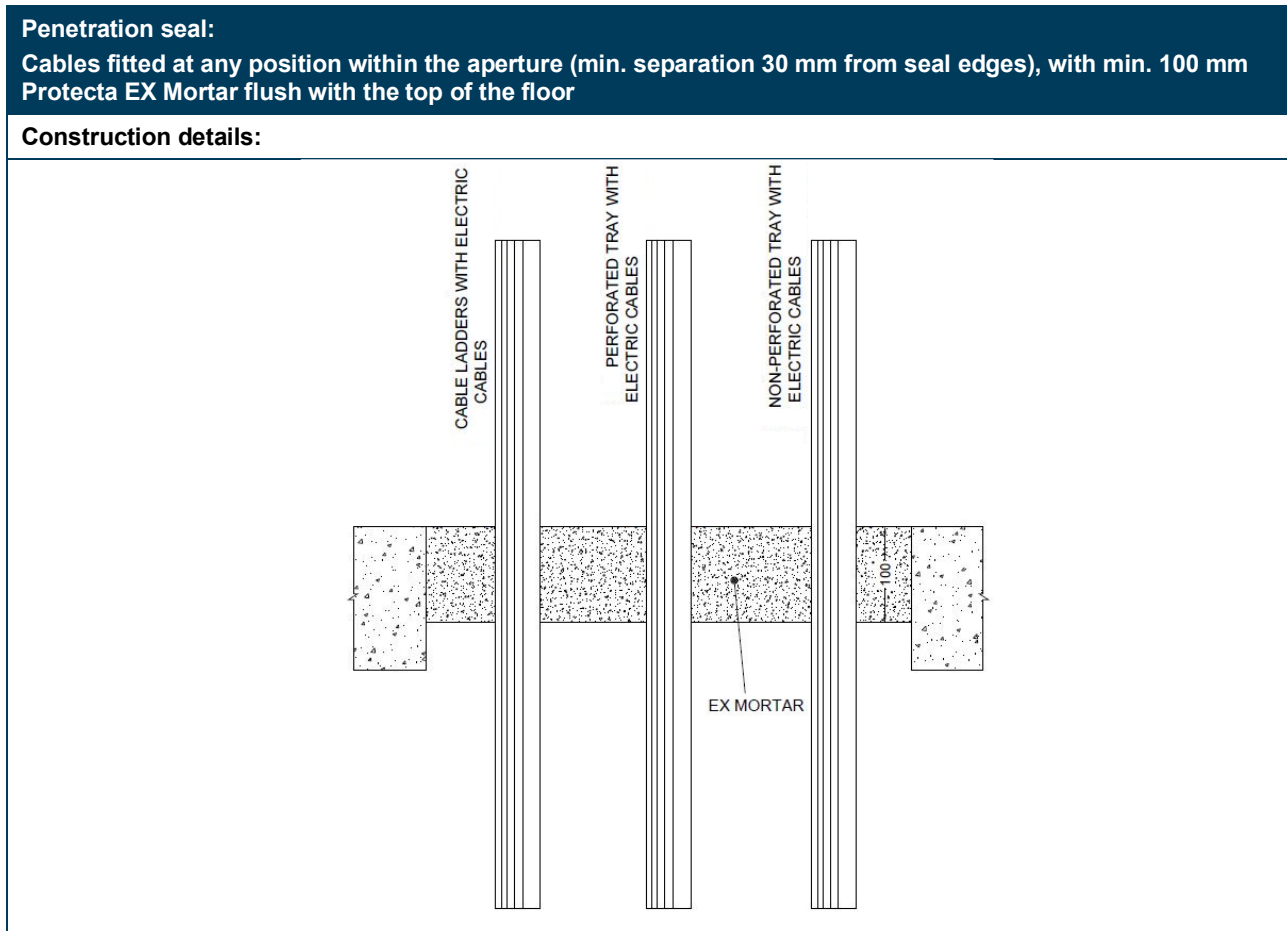

Table 38 Single side penetration seal with cables

Services	Maximum aperture	FRL
None (blank)	As section 4.1 dot point 4	-/240/240
Electrical cables up to Ø 50 mm (single, bundled and on trays)		-/180/60
Electrical cables up to Ø 80 mm (single, bundled and on trays)		-/120/60
Cables up to Ø 21 mm in tied bundles up to 100 mm		-/180/120
Steel cable trays & ladders		-/120/60
Non-sheathed cables up to Ø 17 mm		-/180/90
Non-sheathed cables up to Ø 24 mm		-/180/15
PVC conduits up to Ø 16 mm		-/180/180 C/U, C/C

6.4.5 Pipe penetration seal with 100 mm deep Protecta EX Mortar

Table 39 Construction details

Penetration seal:
 CS (Continuous Sustained) insulated metallic pipes fitted at any position within the aperture (min. separation 25 mm from seal edges and 30 mm from other services), with min. 100 mm Protecta EX Mortar at any position within the floor. Protecta FR Pipes Wraps are required to be fitted around combustible pipe insulation. Maximum seal size as section 4.1 dot point 4.

Construction details:

Table 40 Single side penetration seal with pipes

Services	Wrap	Insulation	FRL
Copper and steel pipes			
12 mm diameter/1 mm wall	50 mm × 3.6 mm Protecta FR Pipe Wrap fitted to the soffit	9 mm Elastomeric insulation minimum class B-s3,d0 or foil faced Phenolic Foam insulation	-/240/240 C/C
12-54 mm diameter/1-1.2 mm wall		13-25 mm Elastomeric insulation minimum class B-s3,d0 or foil faced Phenolic Foam insulation	-/240/60 C/C

Services	Wrap	Insulation	FRL
Alupex pipes			
16 mm diameter/2.25 mm wall	50 mm × 3.6 mm Protecta FR Pipe Wrap fitted to the soffit	9 mm Elastomeric insulation minimum class B-s3,d0 or foil faced Phenolic Foam insulation	-/240/240 C/C
16 mm diameter/2.25 mm wall		9-13 mm Elastomeric insulation minimum class B-s3,d0 or foil faced Phenolic Foam insulation	-/240/90 C/C
20 mm diameter/2.5 mm wall			
26 mm diameter/3 mm wall			
32 mm diameter/3 mm wall			
40 mm diameter/3.5 mm wall			
50 mm diameter/4 mm wall			
63 mm diameter/4.5 mm wall			
75 mm diameter/4.7 mm wall		13-25 mm Elastomeric insulation minimum class B-s3,d0 or foil faced Phenolic Foam insulation	-/180/90 C/C
16 mm diameter/2.25 mm wall			
20 mm diameter/2.5 mm wall			
26 mm diameter/3 mm wall			
32 mm diameter/3 mm wall			
40 mm diameter/3.5 mm wall			
50 mm diameter/4 mm wall			
63 mm diameter/4.5 mm wall			
75 mm diameter/4.7 mm wall			

6.4.6 Pipe penetration seal with Protecta EX Mortar

Table 41 Construction details

<p>Penetration seal: 1000 mm (min.)* LI (Local Interrupted) or CI (Continuous Interrupted) insulated and non-insulated metallic and composite pipes fitted at any position within the aperture (min. separation 30 mm from seal edges), with Protecta EX Mortar to either surface of the floor or anywhere between. Maximum seal size as section 4.1 dot point 4.</p>	
<p>Construction details:</p>	
<p>Configuration 1</p>	<p>Configuration 2</p>
<p>Key: 1 Supporting construction a1 Pipe / top edge of seal separation a2 Pipe / side edge of seal separation a3 Pipe / pipe separation</p>	

Table 42 Single side penetration seal with pipes

Services	Minimum mortar depth and floor thickness	Insulation	FRL
Up to 16 mm diameter steel pipes 1.5- 7 mm wall	100 mm	None	-/240/120 C/C
Up to 63.5 mm diameter steel pipes 1.6- 14.2 mm wall	150 mm		-/180/90 C/U

Services	Minimum mortar depth and floor thickness	Insulation	FRL
Up to 12 mm diameter Copper and steel pipes 0.7-1.5 mm wall	120 mm		-/240/180 C/C
Up to 54 mm diameter Copper and steel pipes 1.5-14.2 mm wall	100 mm		-/120/- C/C
75 mm Alupex composite pipes with 4.6 mm wall	100 mm	None	-/240/- C/C

Table 43 Single side penetration seal with pipes

Services	Minimum mortar depth and floor thickness	Insulation, minimum thickness and density	FRL
Mild or stainless steel pipes			
40 mm diameter/1.5-14.2 mm wall*	100 mm	20 mm Stone wool insulation 80 kg/m ³	-/240/240 C/U
40 mm diameter/1.5-14.2 mm wall*		30 mm Stone wool insulation 80 kg/m ³	-/240/120 C/U
50 mm diameter/1.7-14.2 mm wall*			
60 mm diameter/1.8-14.2 mm wall*			
75 mm diameter/2.1-14.2 mm wall*			
90 mm diameter/2.3-14.2 mm wall*			
100 mm diameter/2.5-14.2 mm wall*			
115 mm diameter/2.8-14.2 mm wall*			
140 mm diameter/3.2-14.2 mm wall*			
165 mm diameter/ 3.6-14.2 mm wall*			
180 mm diameter/ 3.9-14.2 mm wall*			
200 mm diameter/ 4.2-14.2 mm wall*			
219 mm diameter/ 4.5-14.2 mm wall*			
Note: *Typical pipe diameters shown, see below graph in Figure 8 for intermediate sizes			

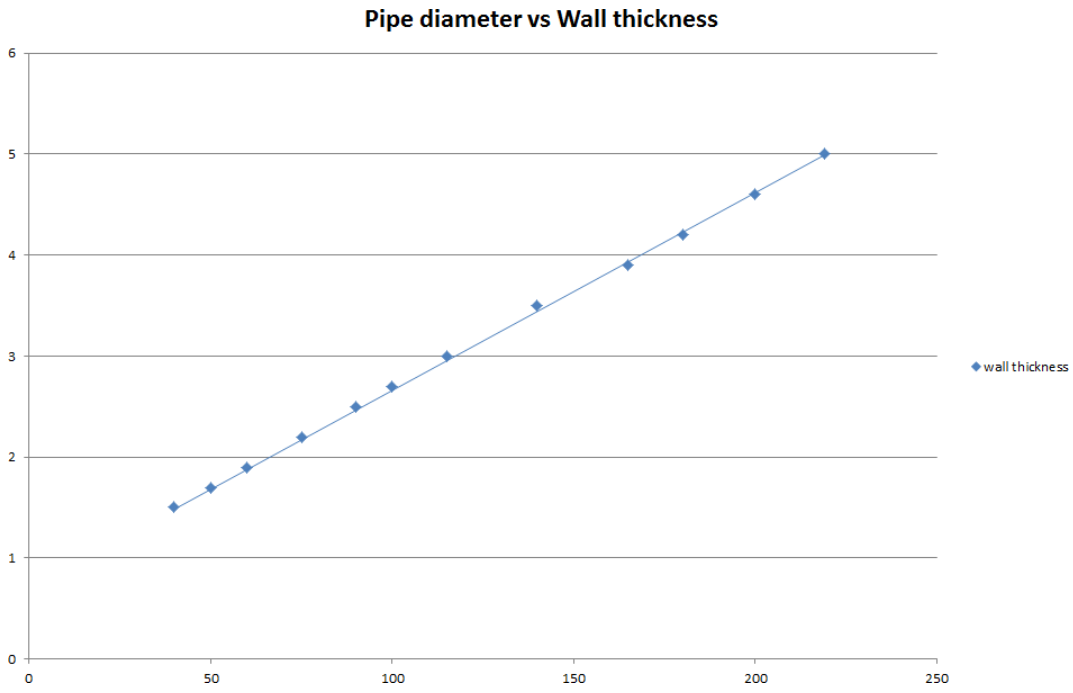

Figure 8 Intermediate pipe wall thicknesses for typical mild or stainless steel pipe diameters

6.4.7 Pipe penetration seal with 100 mm deep Protecta EX Mortar

Table 44 Construction details

Penetration seal: CS (Continuous Sustained) insulated metallic pipes fitted at any position within the aperture (min. separation 30 mm from seal edges and 30 mm from other services), with min. 100 mm Protecta EX Mortar to the top surface of the floor. Protecta FR Pipes Wraps are required to be fitted around combustible pipe insulation. Maximum seal size as section 4.1 dot point 4.
Construction details:

Table 45 Single side penetration seal with pipes

Services	Wrap	Insulation	FRL
Mild or stainless steel pipes			
40 mm diameter/1.5-14.2 mm wall	1 off 50 mm × 1.8 mm Protecta FR Pipe Wrap, fitted at soffit	13 mm Elastomeric insulation minimum class B- s3,d0 or foil faced Phenolic Foam insulation	-/180/180 C/U
40 mm diameter/1.5-14.2 mm wall*		13 -19 mm Elastomeric insulation minimum class B- s3,d0 or foil faced Phenolic Foam insulation	-/180/120 C/U
50 mm diameter/1.6-14.2 mm wall*			
60 mm diameter/1.7-14.2 mm wall*			
75 mm diameter/1.9-14.2 mm wall*			
90 mm diameter/2-14.2 mm wall*			
100 mm diameter/2.1-14.2 mm wall*			
115 mm diameter/2.3-14.2 mm wall*			
140 mm diameter/2.6-14.2 mm wall*			
165 mm diameter/2.8-14.2 mm wall*			
Note: *Typical pipe diameters shown, see below graph in Figure 9 for intermediate sizes			

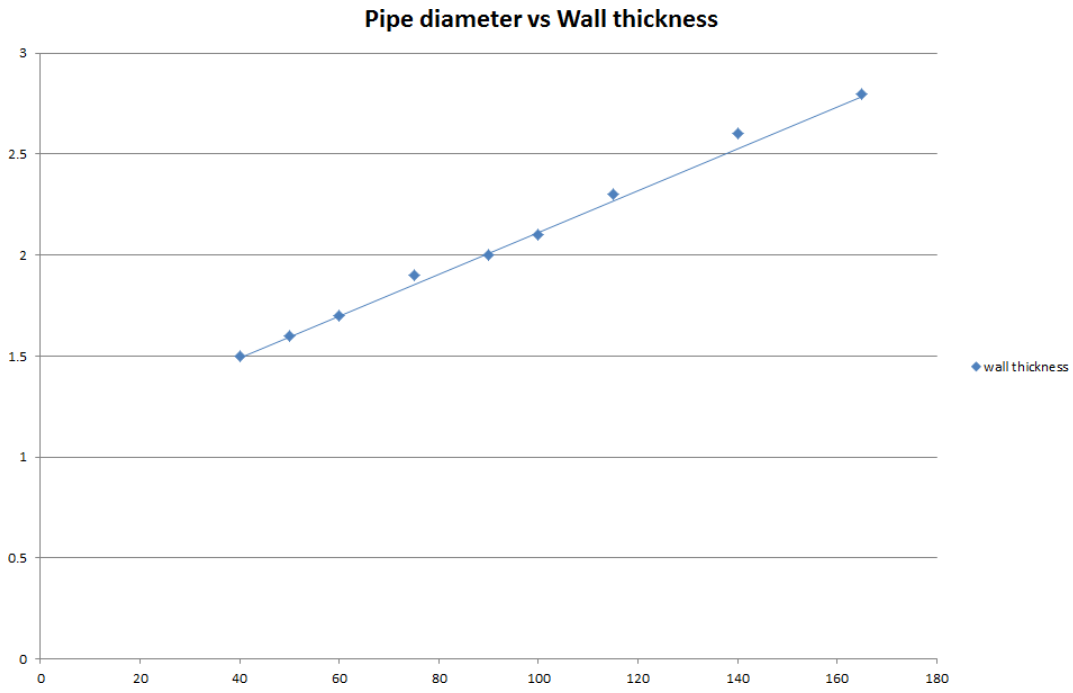

Figure 9 Intermediate pipe wall thicknesses for typical mild or stainless steel pipe diameters

6.4.8 Pipe penetration seal with 100 mm deep Protecta EX Mortar

Table 46 Construction details

<p>Penetration seal: CS (Continuous Sustained) insulated metallic pipes sealed with Protect FR wraps, fitted at any position within the aperture, with min. 100 mm Protecta EX Mortar Seal. Minimum separation between penetration seals and seal edges of 30 mm (Configuration 1 & 2). Maximum seal size as section 4.1 dot point 4.</p>	
<p>Construction details:</p>	
<p>Configuration 1</p>	<p>Configuration 2</p>
<p>Key: 1 Supporting construction a1 Pipe / top edge of seal separation a2 Pipe / side edge of seal separation a3 Pipe / pipe separation</p>	

Table 47 Pipe penetration seal with 100 mm deep Protecta EX Mortar

Services	Insulation	Protecta FR Wrap	FRL
40 mm diameter/1-14.2 mm wall	25 mm thick Elastomeric insulation minimum class B-s3,d0 or foil faced Phenolic Foam insulation	50 mm × 3.6 mm (2 × 1.8 mm layers)	-/240/240 C/U
40 mm diameter/1-14.2 mm wall*	25mm thick Elastomeric insulation minimum class B-s3,d0 or foil faced Phenolic Foam insulation		240/120 C/U
50 mm diameter/1.2-14.2 mm wall*			
60 mm diameter/1.4-14.2 mm wall*			
75 mm diameter/1.6-14.2 mm wall*			
90 mm diameter/1.9-14.2 mm wall*			
100 mm diameter/2.1-14.2 mm wall*			
115 mm diameter/2.4-14.2 mm wall*			
140 mm diameter/2.9-14.2 mm wall*			
165 mm diameter/ 3.4-14.2 mm wall*			
180 mm diameter/ 3.6-14.2 mm wall*			
200 mm diameter/ 4.0-14.2 mm wall*			
219 mm diameter/ 4.3-14.2 mm wall*			
250 mm diameter/ 5.0-14.2 mm wall*			
300 mm diameter/ 5.9-14.2 mm wall*			
324 mm diameter/ 6.35-14.2 mm wall*			
40 mm diameter/1-14.2 mm wall*	25-50mm thick Elastomeric insulation minimum class B-s3,d0 or foil faced Phenolic Foam insulation	50 mm × 5.4 mm (3 × 1.8 mm layers)	-/120/120 C/U
50 mm diameter/1.2-14.2 mm wall*			
60 mm diameter/1.4-14.2 mm wall*			
75 mm diameter/1.6-14.2 mm wall*			
90 mm diameter/1.9-14.2 mm wall*			
100 mm diameter/2.1-14.2 mm wall*			
115 mm diameter/2.4-14.2 mm wall*			
140 mm diameter/2.9-14.2 mm wall*			
165 mm diameter/ 3.4-14.2 mm wall*			
180 mm diameter/ 3.6-14.2 mm wall*			
200 mm diameter/ 4.0-14.2 mm wall*			
219 mm diameter/ 4.3-14.2 mm wall*			
250 mm diameter/ 5.0-14.2 mm wall*			
300 mm diameter/ 5.9-14.2 mm wall*			
324 mm diameter/ 6.35-14.2 mm wall*			
<p>Note:</p> <p>*Typical pipe diameters shown, see graph in Figure 10 for intermediate sizes</p>			

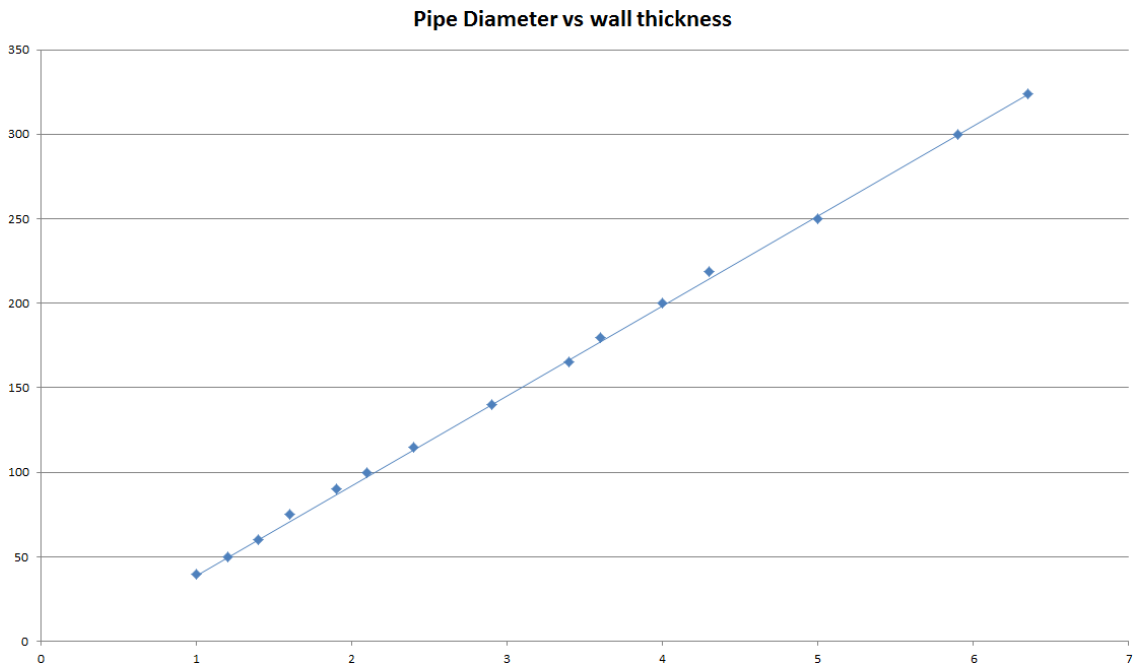

Figure 10 Intermediate pipe wall thicknesses for typical mild or stainless steel pipe diameters

6.4.9 Pipe penetration seal with 100 mm deep Protecta EX Mortar

Table 48 Construction details

<p>Penetration seal: Plastic pipes fitted at any position within the aperture, with min. 100 mm Protecta EX Mortar to the either surface of the floor or anywhere between. Protecta FR Pipe wraps are required to be fitted to the bottom of the seal, as indicated below. Minimum separation between penetration seals and seal edges of 30 mm (Configuration 1 & 2).</p>	
<p>Construction details:</p>	
<p>Configuration 1</p>	<p>Configuration 2</p>
<p>Key: 1 Supporting construction a1 Pipe / top edge of seal separation a2 Pipe / side edge of seal separation a3 Pipe / pipe separation</p>	

Table 49 Single side penetration seal with pipes

Services	Wrap	Maximum aperture	FRL
PVC-U pipes			
Up to 40 mm diameter / 1.8-3.7 mm wall	50 mm × 1.8 mm	As section 4.1 dot point 4.	-/180/120 U/U
Up to 110 mm diameter / 3.0-6.6 mm wall	50 mm × 3.6 mm		-/240/240 U/C
Up to 125 mm diameter / 3.5-7.4 mm wall	50 mm × 7.2 mm		-/120/120 U/C
Up to 160 mm diameter / 4.5 mm wall	50 mm × 10.8 mm		-/240/240 C/C
Up to 160 mm diameter / 4.5-9.5 mm wall	50 mm × 10.8 mm		-/90/90 C/C
Up to 110 mm diameter/ 2.7-6.6 mm wall, containing up to Ø 90 mm bundle of up to Ø 14 mm cables	50 mm × 3.6 mm		-/120/120 U/C
PP pipes			
Up to 40 mm diameter /1.8-4.4 mm wall	None	As section 4.1 dot point 4.	-/120/120 U/C
Up to 40 mm diameter /1.8-5.5 mm wall	50 mm × 1.8 mm		-/120/120 U/U
Up to 50 mm diameter /2.5-5.5 mm wall	50 mm × 3.6 mm		-/240/240 C/C
Up to 75 mm diameter /3.5-5.5 mm wall	50 mm × 3.6 mm		-/240/240 C/C
Up to 110 mm diameter /2.7-6.3 mm wall	50 mm × 3.6 mm		-/240/240 U/C
Up to 125 mm diameter /3.4-11.4 mm wall	50 mm × 7.2 mm		-/240/240 U/C
Up to 160 mm diameter /4.9-14.6 mm wall	50 mm × 10.8 mm		-/240/240 U/C
Up to 110 mm diameter/ 3.4-6.3 mm wall, containing up to Ø 90 mm bundle of up to Ø 14 mm cables	50 mm × 3.6 mm		-/60/60 U/C
PE pipes			
Up to 40 mm diameter / 2.0-4.4 mm wall	None	As section 4.1 dot point 4.	-/120/120 U/C
Up to 40 mm diameter / 2.4-3.7 mm wall	50 mm × 1.8 mm		-/240/240 U/U
Up to 110 mm diameter / 3.4-10.0 mm wall	50 mm × 3.6 mm		-/120/120 U/C
Up to 125 mm diameter / 3.9-11.4 mm wall	50 mm × 7.2 mm		-/240/240 U/C
Up to 160 mm diameter / 4.9-14.6 mm wall	50 mm × 10.8 mm		-/120/120 U/C
Up to 250 mm diameter / 7.8 mm wall	75 mm × 12.6 mm		-/180/180 C/C
Up to 110 mm diameter/ 2.7-10.0 mm wall, containing up to Ø 90 mm bundle of up to Ø 14 mm cables	50 mm × 3.6 mm		-/120/60 U/C

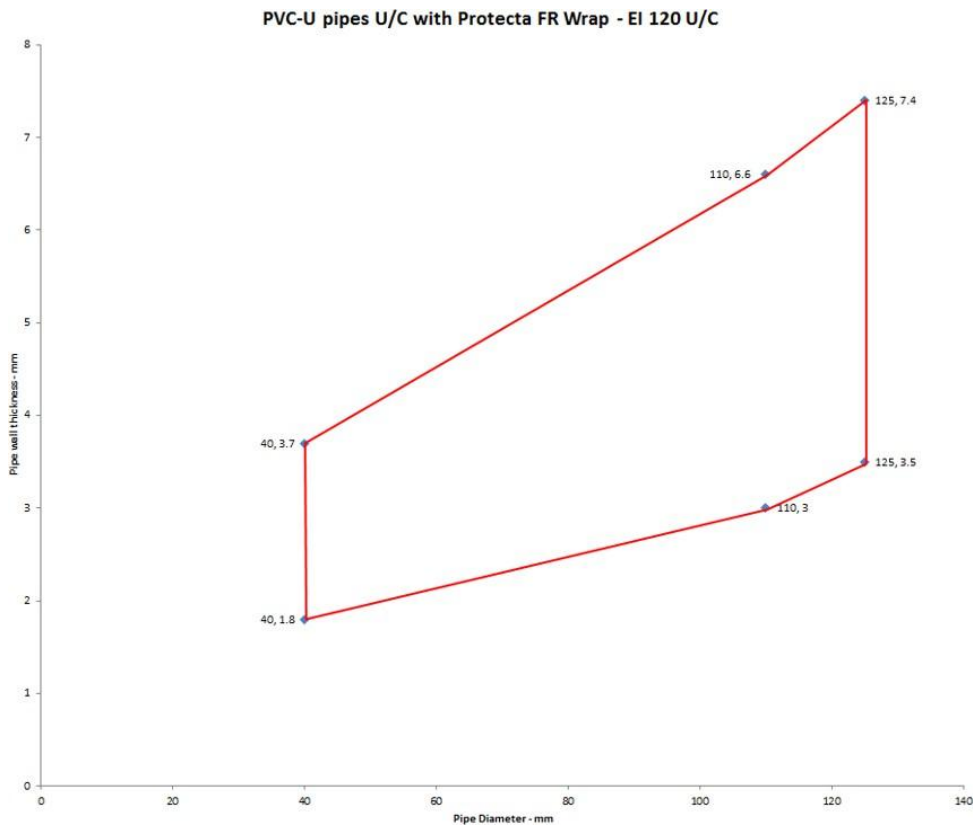

Figure 11 Intermediate pipe wall thicknesses for typical PVC-U pipe diameters with Protecta FR Wrap

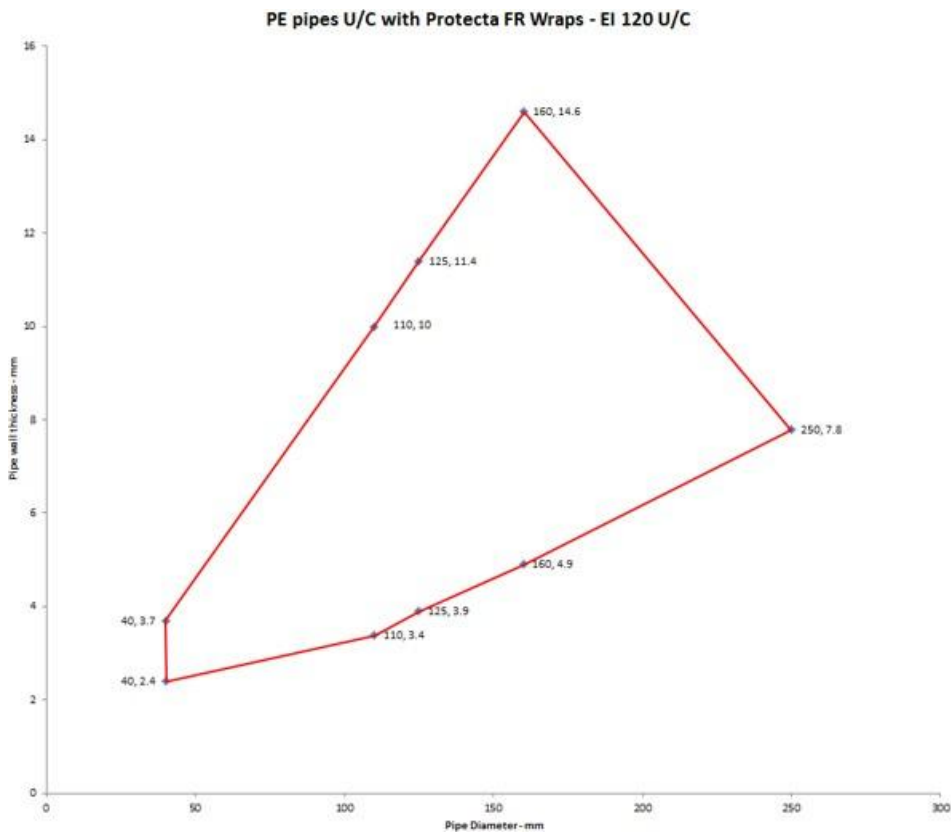

Figure 12 Intermediate pipe wall thicknesses for typical PE pipe diameters with Protecta FR Wrap

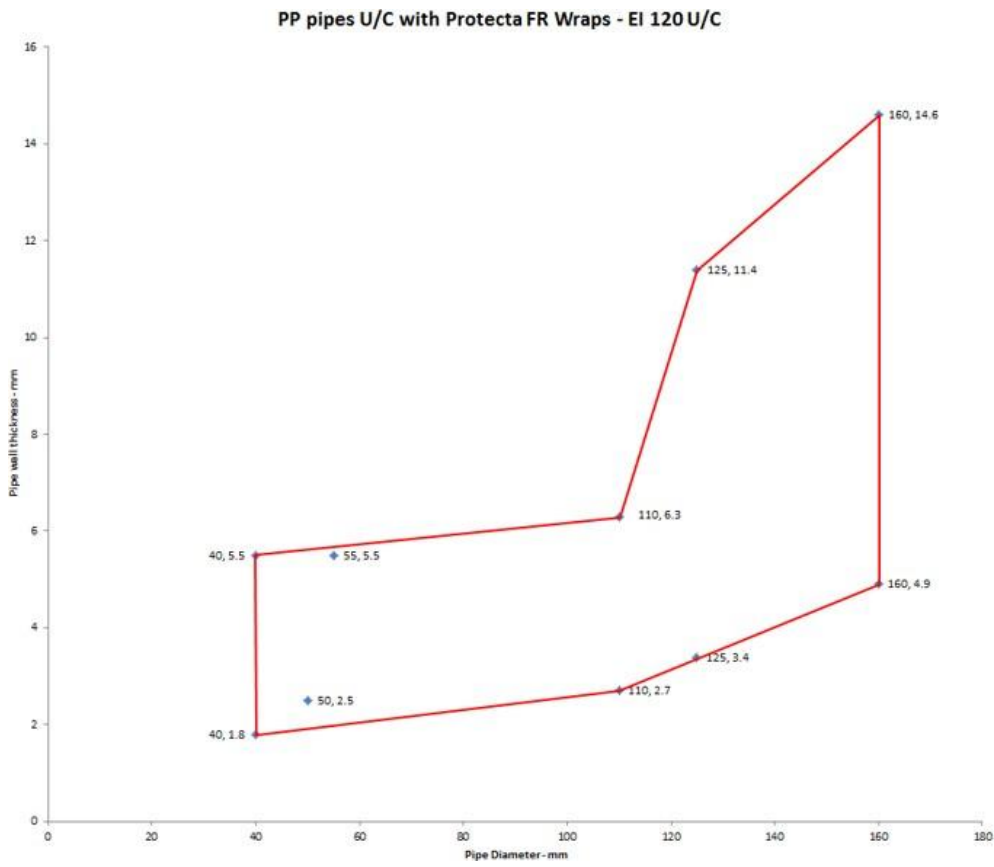

Figure 13 Intermediate pipe wall thicknesses for typical PP pipe diameters with Protecta FR

6.4.10 Pipe penetration seal with 100 mm deep Protecta EX Mortar

Table 50 Construction details

<p>Penetration seal: Plastic pipes fitted at any position within the aperture (min. separation 30 mm from seal edges and from other services), with min. 100 mm Protecta EX Mortar to either surface of the floor or anywhere between. Protecta FR Pipe Wraps are required to be fitted to the bottom of the seal, as indicated below. Maximum seal size as section 4.1 dot point 4.</p>	
<p>Construction details:</p>	
<p>Configuration 1</p>	<p>Configuration 2</p>
<p>Key: 1 Supporting construction a1 Pipe / top edge of seal separation a2 Pipe / side edge of seal separation a3 Pipe / pipe separation</p>	

Table 51 Pipe penetration seal with 100 mm deep Protecta EX Mortar

Services	Wrap	Permitted configuration for seal separation	FRL
PVC-U pipes			
160 mm diameter / 9.5 mm wall	50 mm × 10.8 mm (6 × 1.8 mm layers)	1 & 2	-/90/90 U/C
PEX pipe in pipe systems			

Services	Wrap	Permitted configuration for seal separation	FRL
Maximum 54 mm diameter/0.4 mm wall thickness (outer pipe), 28 mm diameter/4.0 mm wall thickness (inner pipe)	50 mm × 3.6 mm (2 × 1.8 mm layers)	1 & 2	-/120/120 C/C
Rehau Raupiano Plus PP-DD			
40-50 mm diameter/1.8-2.7 mm wall thickness*	50 mm × 3.6 mm (2 × 1.8 mm layers)	1 & 2	-/120/120 U/U
75-110 mm diameter/2.7 mm wall thickness*	50 mm × 3.6 mm (2 × 1.8 mm layers)	1 & 2	-/120/120 U/C
125 mm diameter/3.1 mm wall thickness	50 mm × 7.2 mm (4 × 1.8 mm layers)	1 & 2	-/240/120 U/C
160 mm diameter/3.9 mm wall thickness	50 mm × 10.8 mm (6 × 1.8 mm layers)	1 & 2	-/120/120 U/C
Polo-Kal NG Poloplast PP-MV			
32-110 mm diameter/3.4 mm wall thickness	50 mm × 3.6 mm (2 × 1.8 mm layers)	1 & 2	-/180/180 U/C
125 mm diameter/3.9 mm wall thickness	50 mm × 7.2 mm (4 × 1.8 mm layers)	1 & 2	-/240/240 U/C
160 mm diameter/4.3 mm wall thickness	50 mm × 10.8 mm (6 × 1.8 mm layers)	1 & 2	-/240/240 U/C
Aquatherm Green SDR9 MF PP-RP			
32 mm diameter/3.6 mm wall thickness	50 mm × 1.8 mm (1 × 1.8 mm layers)	1 & 2	-/240/240 C/C
40-50 mm diameter/5.6-12.3 mm wall thickness*	50 mm × 3.6 mm (2 × 1.8 mm layers)	1 & 2	-/240/240 C/C
63-110 mm diameter/12.3 mm wall thickness*	50 mm × 3.6 mm (2 × 1.8 mm layers)	1 & 2	-/240/240 C/C
Wavin SiTech + PP-M B			
32-50 mm diameter/1.8-3.4 mm wall thickness*	50 mm × 3.6 mm (2 × 1.8 mm layers)	1 & 2	-/120/120 U/U
75-110 mm diameter/3.4 mm wall thickness*	50 mm × 3.6 mm (2 × 1.8 mm layers)	1 & 2	-/120/120 U/C
Gilbert Silent PP			
32-50 mm diameter/1.8-3.4 mm wall thickness*	50 mm × 3.6 mm (2 × 1.8 mm layers)	1 & 2	-/120/120U/U
75-110 mm diameter/3.4 mm wall thickness*	50 mm × 3.6 mm (2 × 1.8 mm layers)	1 & 2	-/120/120 U/C
Blue Power Multilayer pipes			
32-50 mm diameter*	50 mm × 3.6 mm (2 × 1.8 mm layers)	1 & 2	-/240/240 U/U

Services	Wrap	Permitted configuration for seal separation	FRL
75-110 mm diameter*	50 mm × 3.6 mm (2 × 1.8 mm layers)	1 & 2	-/120/120 U/C
125 mm diameter/3.9 mm wall thickness*	50 mm × 7.2 mm (4 × 1.8 mm layers)	1 & 2	-/120/120 U/C
160 mm diameter/4.9 mm wall thickness*	50 mm × 10.8 mm (6 × 1.8 mm layers)	1 & 2	-/240/240 U/C
Uponor Decibel pipes			
32-50 mm diameter*	50 mm × 3.6 mm (2 × 1.8 mm layers)	1 & 2	-/120/120 U/U
75-110 mm diameter*	50 mm × 3.6 mm (2 × 1.8 mm layers)	1 & 2	-/120/120 U/C
Note: *Typical pipe diameters shown, see below graphs in Figure 14 to Figure 19 for intermediate sizes			

Rehau Raupiano Plus -EI 120 U/U

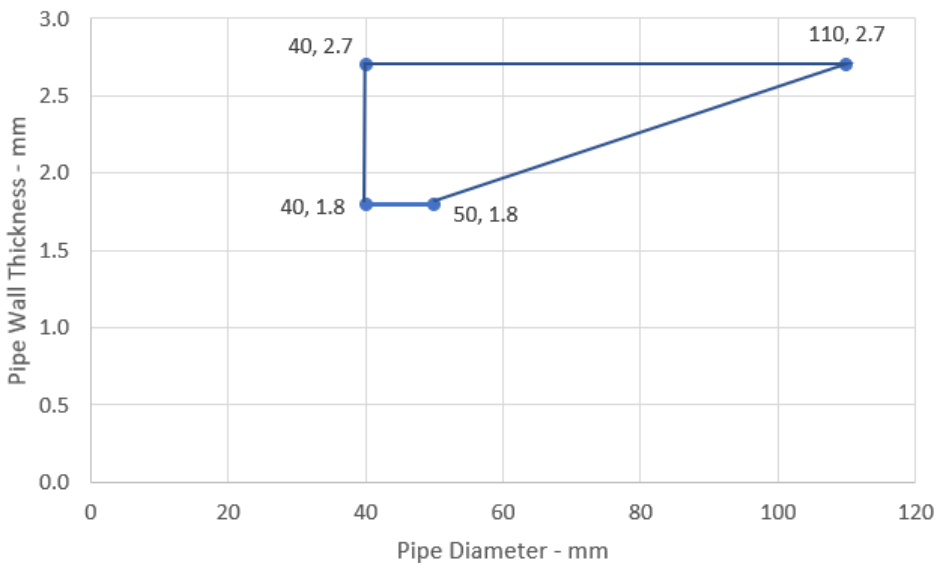

Figure 14 Intermediate pipe wall thicknesses for Rehau Raupiano Plus pipe diameters

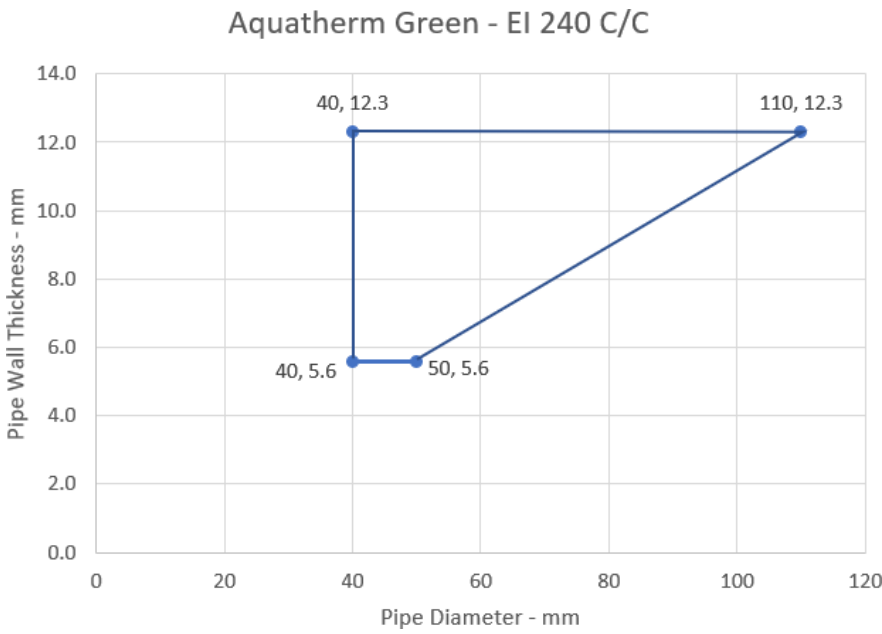

Figure 15 Intermediate pipe wall thicknesses for Aquatherm Green pipe diameters

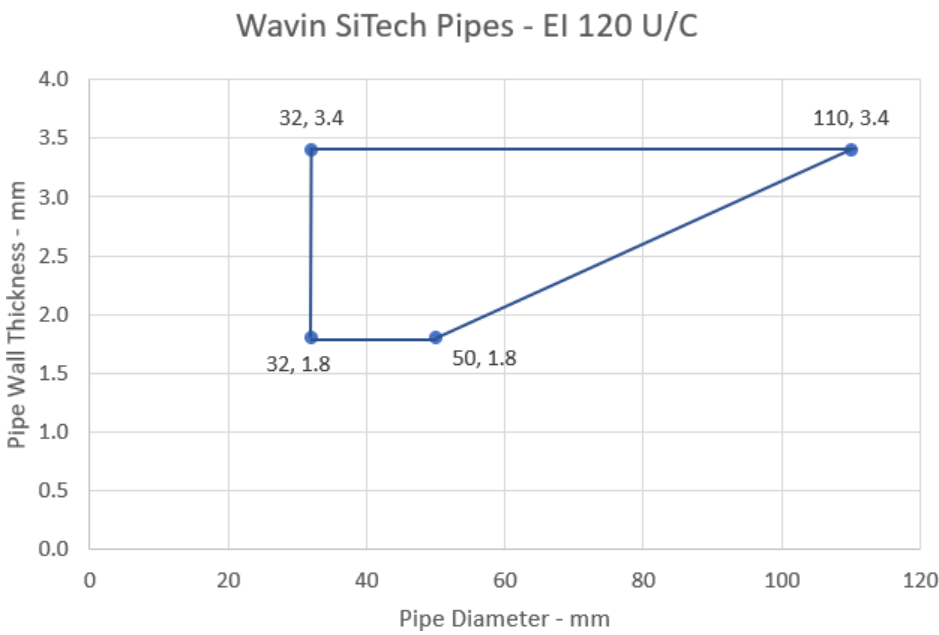

Figure 16 Intermediate pipe wall thicknesses for Wavin SiTech pipe diameters

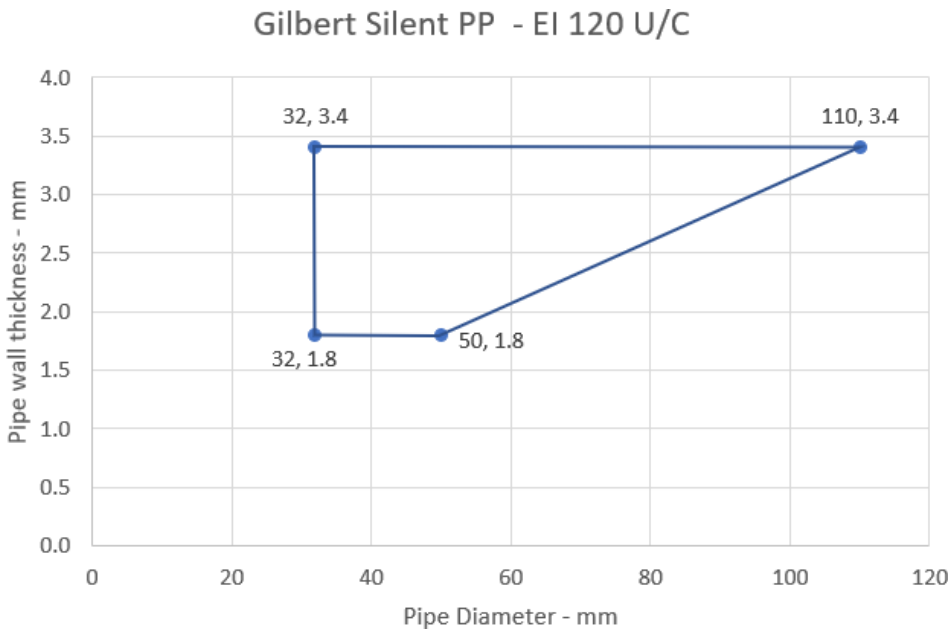

Figure 17 Intermediate pipe wall thicknesses for Gilbert Silent PP pipe diameters

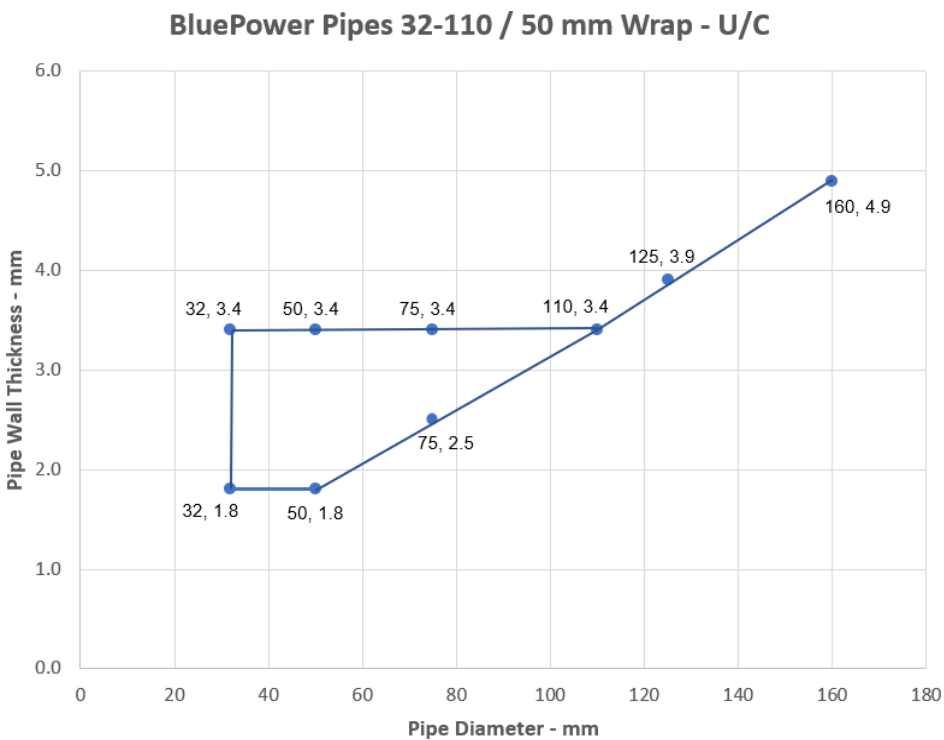

Figure 18 Intermediate pipe wall thicknesses for BluePower pipe diameters

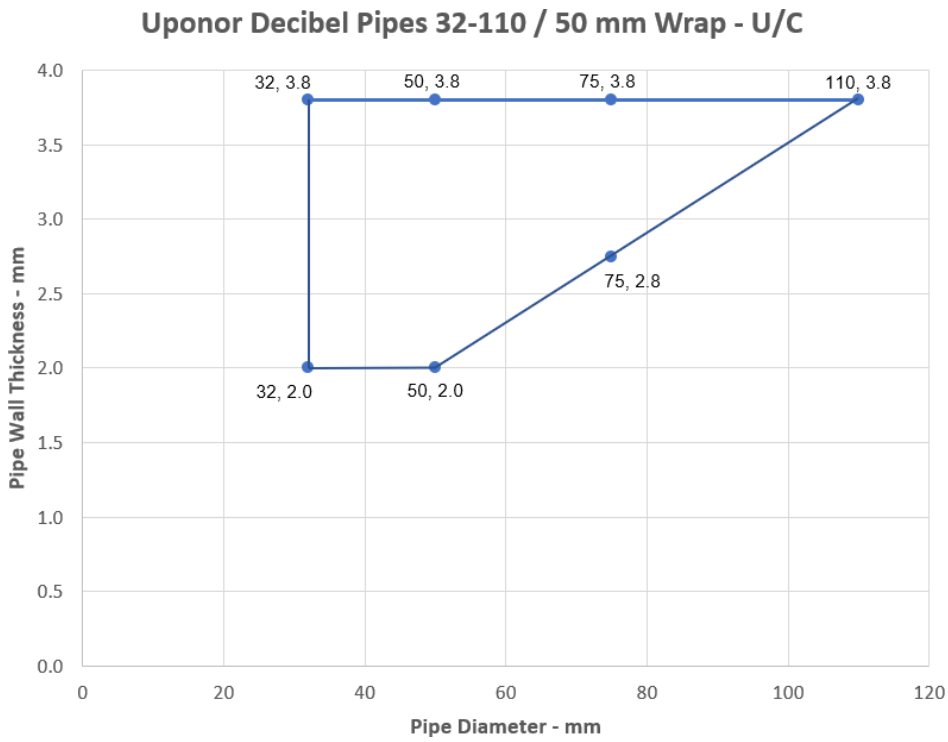

Figure 19 Intermediate pipe wall thicknesses for Uponor Decibel pipe diameters

6.4.11 Pipe penetration seal with Protecta EX Mortar

Table 52 Construction details

<p>Penetration seal: Plastic pipes fitted at any position within the aperture (min. separation 30 mm from seal edges and from other services), with Protecta EX Mortar to either surface of the floor or anywhere between. Protecta FR Pipe Wraps are required to be fitted to the bottom of the seal, as indicated below. Maximum seal size as section 4.1 dot point 4.</p>	
<p>Construction details:</p>	
<p>Configuration 1</p>	<p>Configuration 2</p>
<p>Key: 1 Supporting construction a1 Pipe / top edge of seal separation a2 Pipe / side edge of seal separation a3 Pipe / pipe separation</p>	

Table 53 Pipe penetration seal with Protecta EX Mortar

Services	Wrap	Permitted configuration for seal separation	Min. mortar depth and floor thickness	FRL
PVC-U pipes				
Diameter 41 mm, wall thickness 1.8-3.7 mm to diameter 125 mm, wall thickness 4.8-7.4 mm*	50 mm × 7.2 mm (4 × 1.8 layers)	1 & 2	150 mm	-/60/60 U/U
125 mm diameter / 7.4 mm wall	50 mm × 7.2 mm (4 × 1.8 layers)	1 & 2	150 mm	-/120/120 U/U
Diameter 126 mm, wall thickness 4.8-7.4 mm to diameter 160 mm, wall thickness 9.5 mm*	75 mm × 10.8 mm (6 × 1.8 layers)	1	150 mm	-/120/30 U/U
160 mm diameter / 9.5 mm wall	75 mm × 7.2 mm (4 × 1.8 layers)	1	150 mm	-/120/30 U/U
160 mm diameter / 4.5-9.5 mm wall thickness	50 mm × 10.8 mm (6 × 1.8 layers)	1 & 2	120 mm	-/120/120 U/C, C/C
Diameter 161 mm, wall thickness 4.5-9.5 mm to diameter 200 mm, wall thickness 4.9-11.9 mm*	75 mm × 10.8 mm (6 × 1.8 layers)	1 & 2	120 mm	-/120/120 C/C
200 mm diameter / 4.9-11.9 mm wall thickness	75 mm × 10.8 mm (6 × 1.8 layers)	1 & 2	120 mm	-/240/240 C/C
Diameter 201 mm, wall thickness 4.9-11.9 mm to diameter 315 mm, wall thickness 7.7 mm*	75 mm × 18 mm (10 × 1.8 layers)	1	120 mm	-/120/120 C/C
315 mm diameter / 7.7 mm wall thickness	75 mm × 18 mm (10 × 1.8 layers)	1	120 mm	-/120/120 C/C
Diameter 161 mm, wall thickness 4.5-9.5 mm to diameter 315 mm, wall thickness 7.7-12.1 mm*	75 mm × 18 mm (10 × 1.8 layers)	1	120 mm	-/90/90 C/C
315 mm diameter / 12.1 mm wall thickness	75 mm × 18 mm (10 × 1.8 layers)	1	120 mm	-/90/90 C/C
Diameter 315 mm, wall thickness 7.7-12.1 mm to diameter 400 mm, wall thickness 15.3 mm*	75 mm × 28.8 mm (16 × 1.8 layers)	1	120 mm	-/60/60 C/C
400mm diameter / 15.3 mm wall thickness	75 mm × 28.8 mm (16 × 1.8 layers)	1 & 2	120 mm	-/60/60 C/C
Note: *Typical pipe diameters shown, see below graphs in Figure 20 to Figure 25 for intermediate sizes				

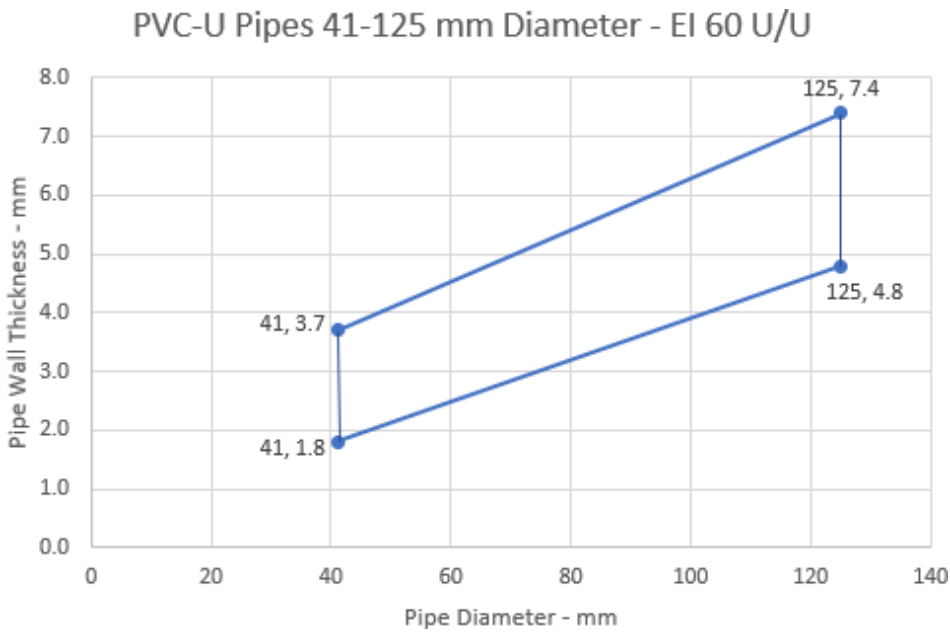

Figure 20 Intermediate pipe wall thicknesses for PVC-U pipe diameters from 41-125 mm

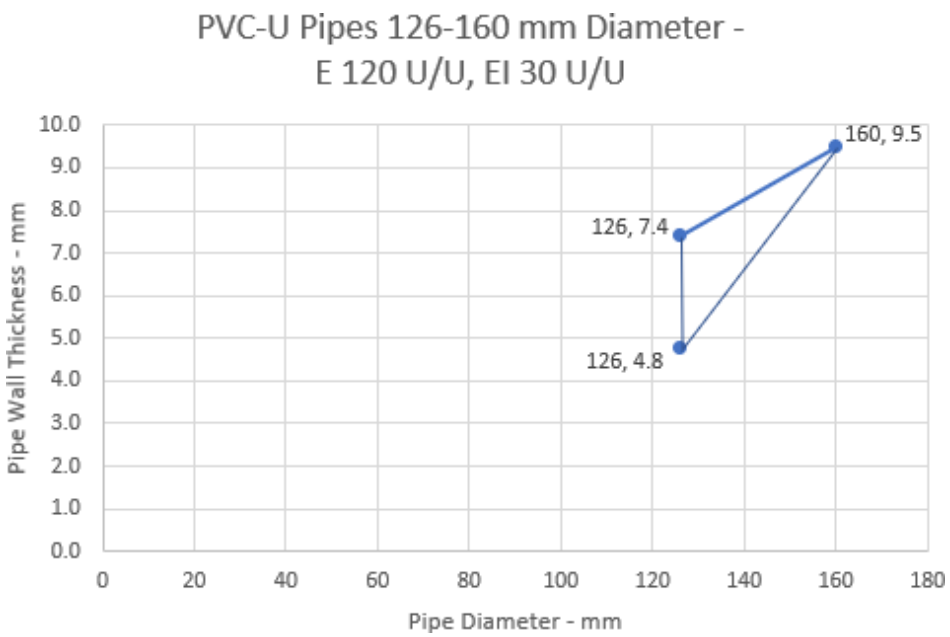

Figure 21 Intermediate pipe wall thicknesses for PVC-U pipe diameters from 126-160 mm

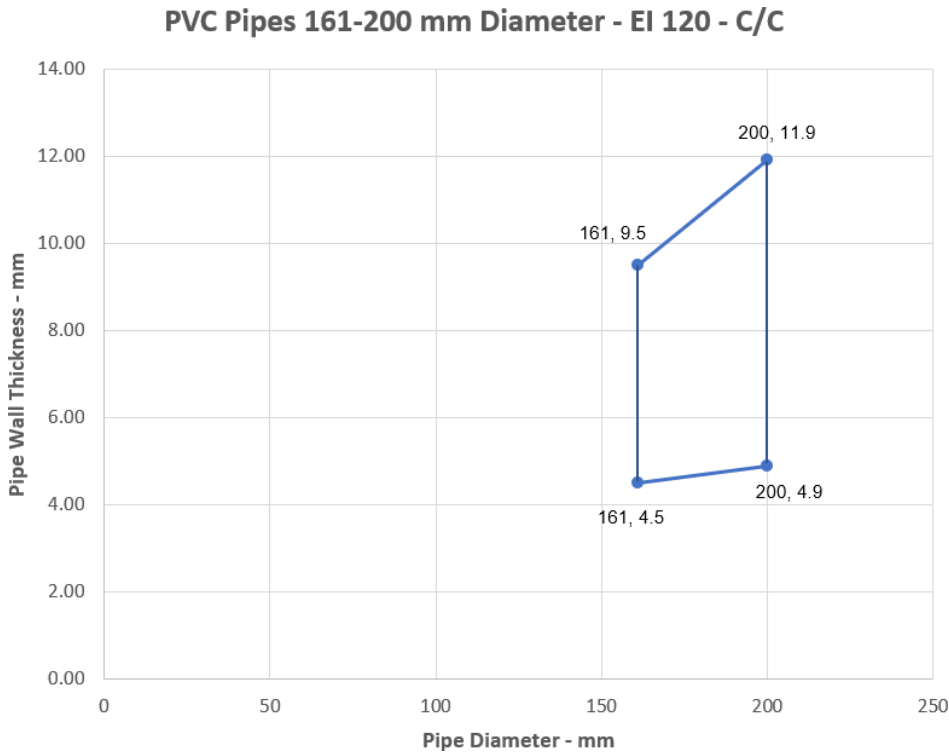

Figure 22 Intermediate pipe wall thicknesses for PVC-U pipe diameters from 161-200 mm

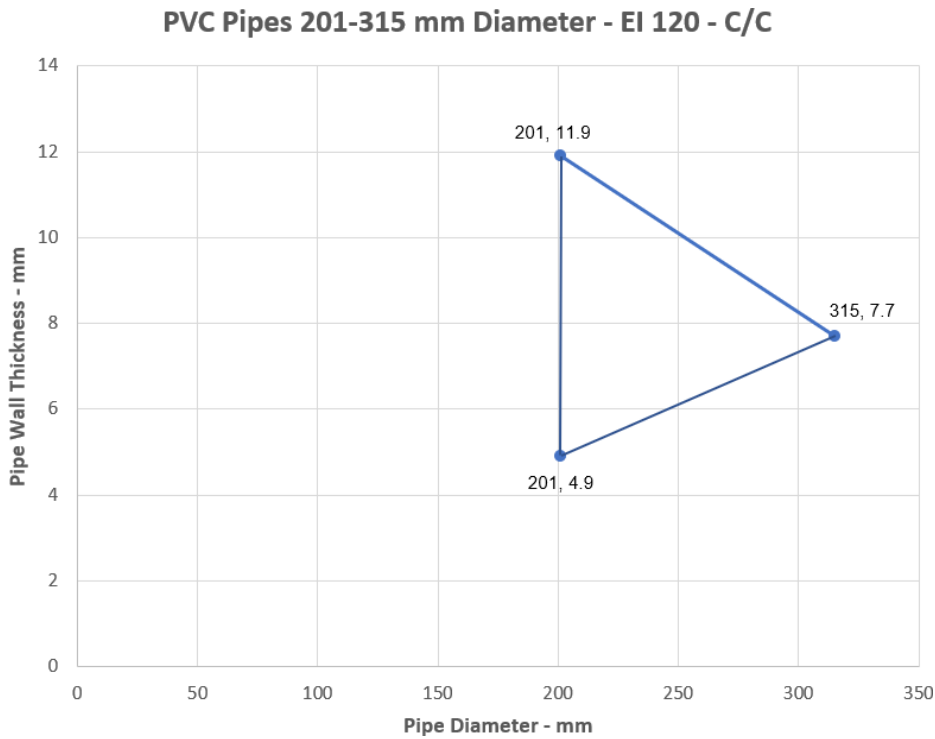

Figure 23 Intermediate pipe wall thicknesses for PVC-U pipe diameters from 201-315 mm

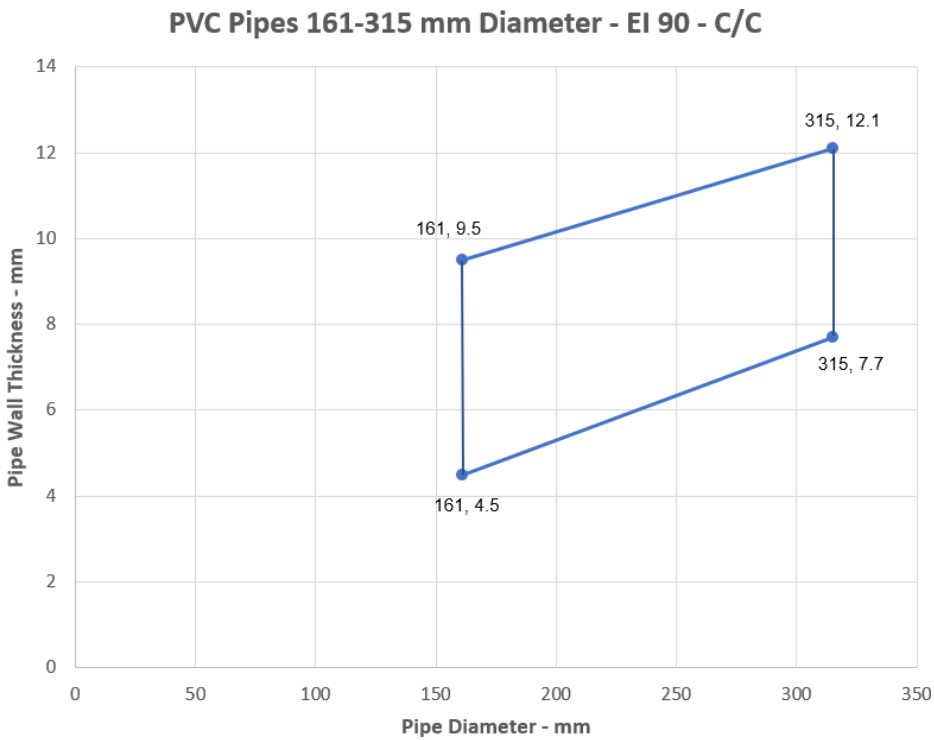

Figure 24 Intermediate pipe wall thicknesses for PVC-U pipe diameters from 161-315 mm

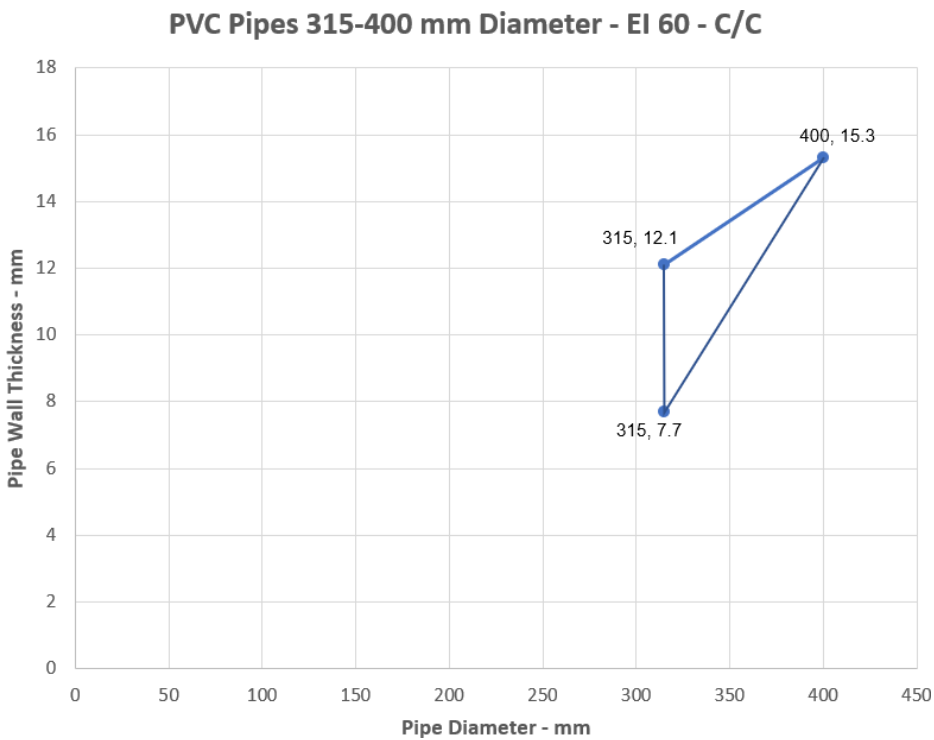

Figure 25 Intermediate pipe wall thicknesses for PVC-U pipe diameters from 315-400 mm

Table 54 Pipe penetration seal with Protecta EX Mortar

Services	Wrap	Permitted configuration for seal separation	Min. mortar depth and floor thickness	FRL
PP pipes				
Diameter 41 mm, wall thickness 1.8-5.5 mm to diameter 160 mm, wall thickness 4.9-14.6 mm*	75 mm × 10.8 mm (6 × 1.8 layers)	1 & 2	150 mm	-/120/120 U/C
160 mm diameter / 14.6 mm wall	75 mm × 7.2 mm (4 × 1.8 layers)	1 & 2	150 mm	-/240/240 U/U
Diameter 161 mm, wall thickness 4.9-14.6 mm to diameter 200 mm, wall thickness 4.9-18.2 mm*	75 mm × 10.8 mm (6 × 1.8 layers)	1 & 2	120 mm	-/240/240 C/C
Diameter 201 mm, wall thickness 4.9-18.2 mm to diameter 315 mm, wall thickness 7.7 mm*	75 mm × 18 mm (10 × 1.8 layers)	N/A	150 mm	-/180/180 C/C
Diameter 201 mm, wall thickness 4.9-18.2 mm to diameter 315 mm, wall thickness 7.7-28.6 mm*	75 mm × 18 mm (10 × 1.8 layers)	N/A	150 mm	-/60/60 C/C
315 mm diameter / 7.7 mm wall	75 mm × 18 mm (10 × 1.8 layers)	N/A	150 mm	-/180/180 C/C
315 mm diameter / 7.7-28.6 mm wall	75 mm × 18 mm (10 × 1.8 layers)	1	150 mm	-/60/60 C/C
Diameter 315 mm, wall thickness 7.7-28.6 mm to diameter 400 mm, wall thickness 22.7 mm*	75 mm × 28.8 mm (16 × 1.8 layers)	1	150 mm	-/60/60 C/C
400mm diameter / 22.7 mm wall thickness	75 mm × 28.8 mm (16 × 1.8 layers)	1 & 2	150 mm	-/60/60 C/C
Note: *Typical pipe diameters shown, see below graphs in Figure 26 to Figure 30 for intermediate sizes				

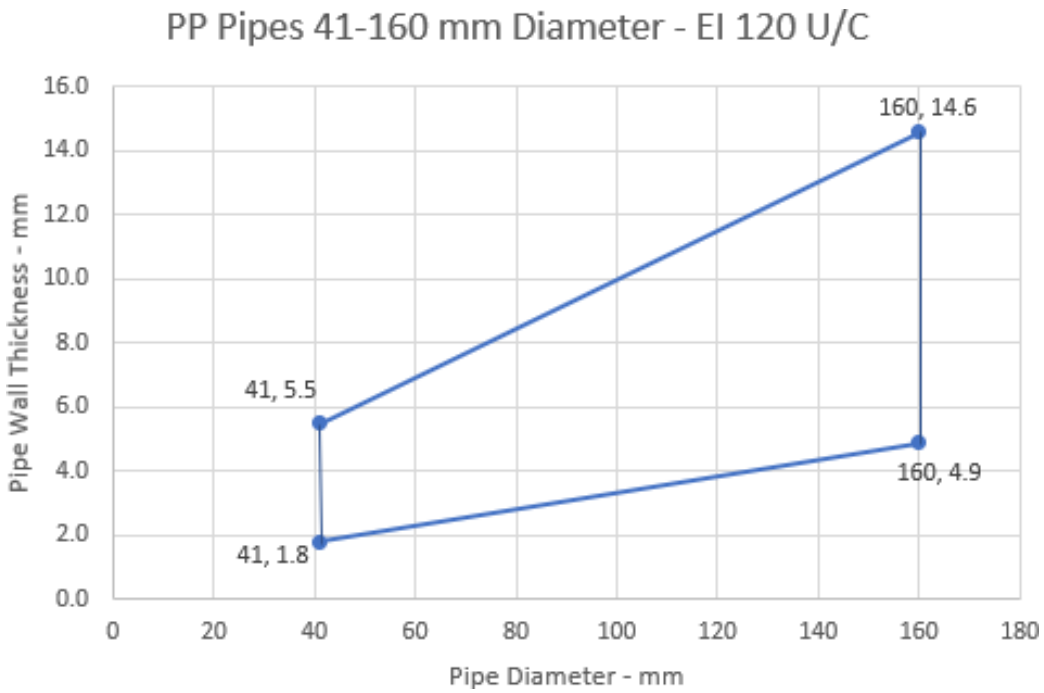

Figure 26 Intermediate pipe wall thicknesses for PP pipe diameters from 41-160 mm

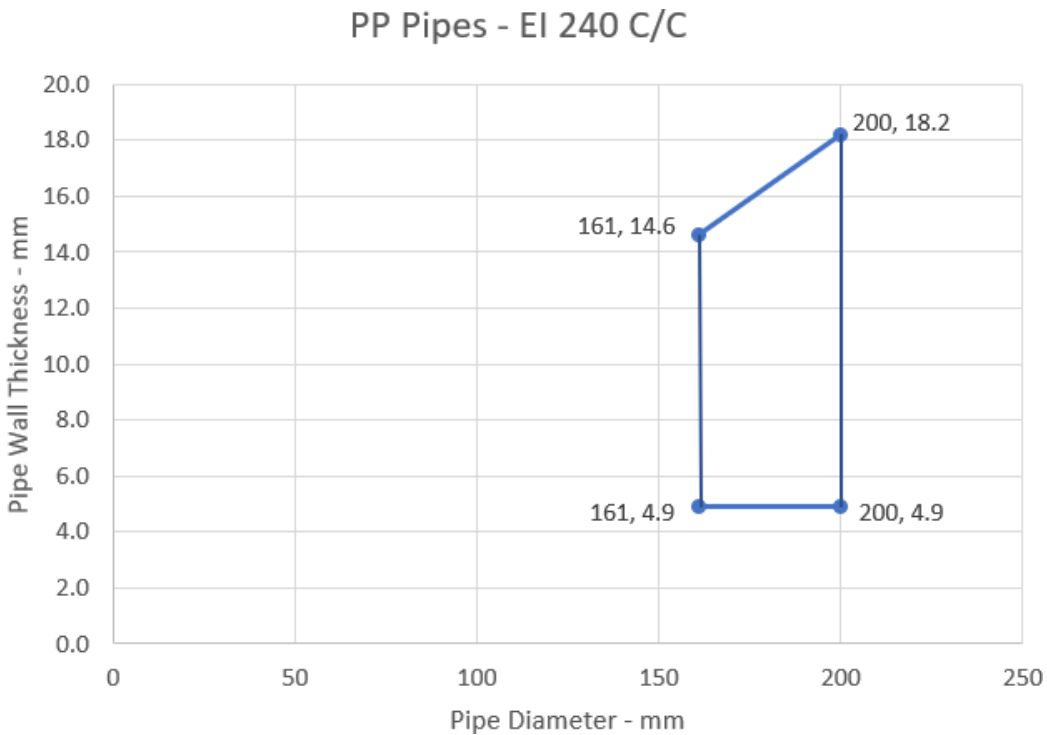

Figure 27 Intermediate pipe wall thicknesses for PP pipe diameters from 161-200 mm

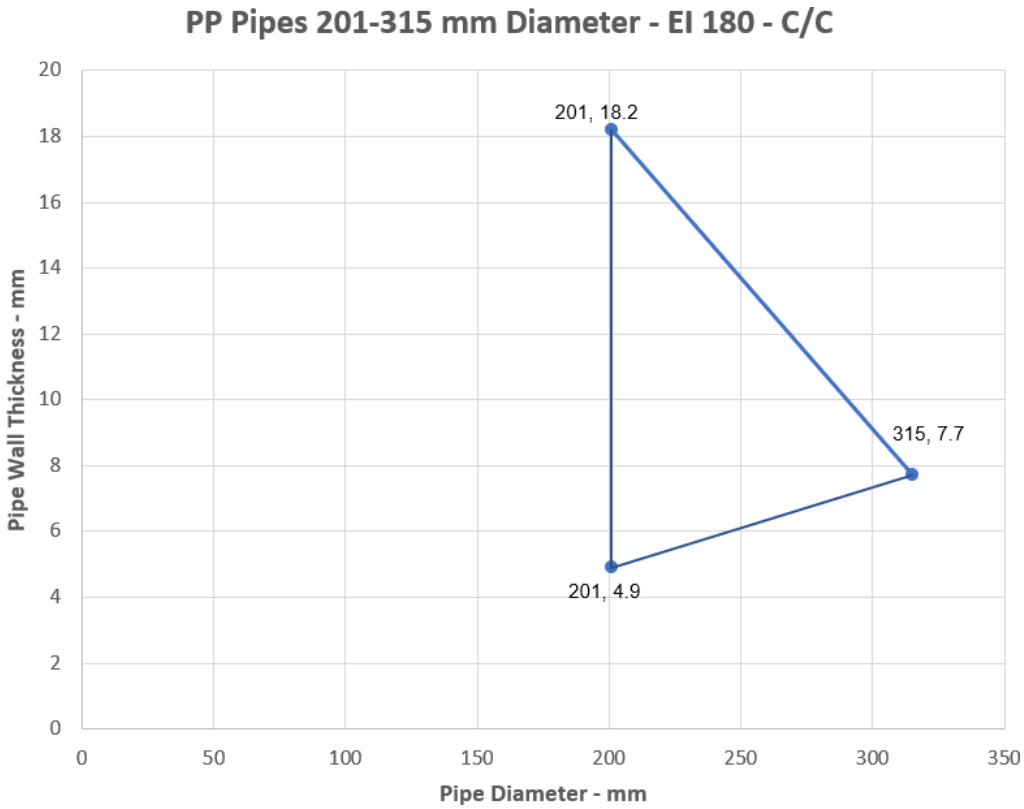

Figure 28 Intermediate pipe wall thicknesses for PP pipe diameters from 201-315 mm

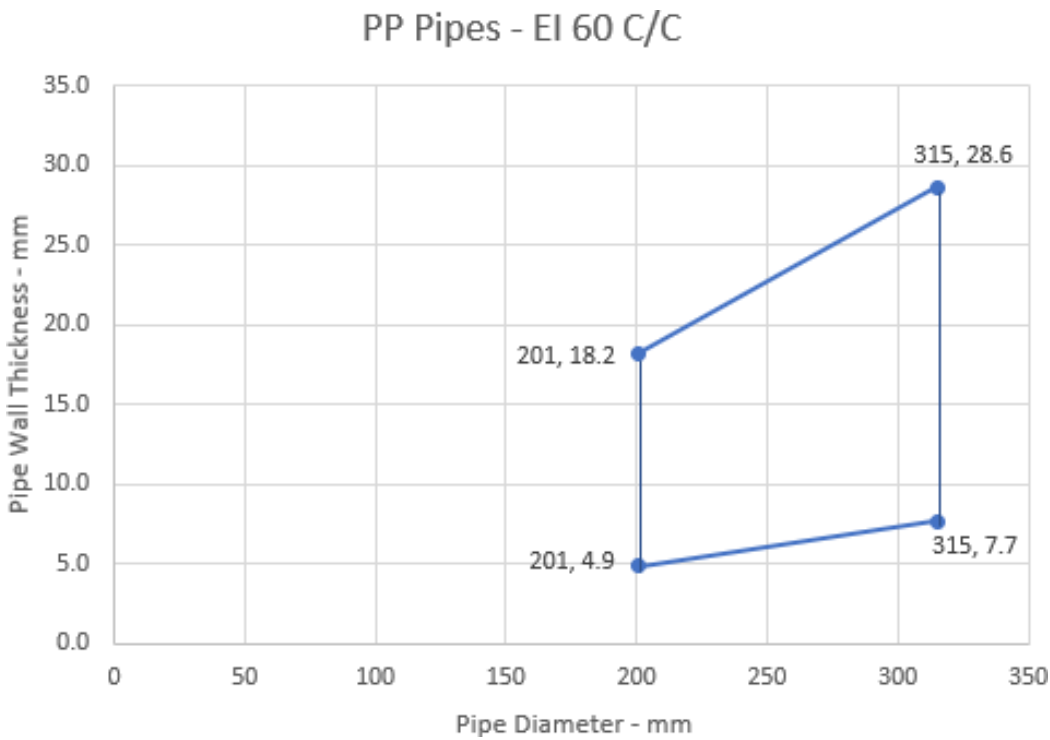

Figure 29 Intermediate pipe wall thicknesses for PP pipe diameters from 201-315 mm

PP Pipes 315-400 mm Diameter - EI 60 - C/C

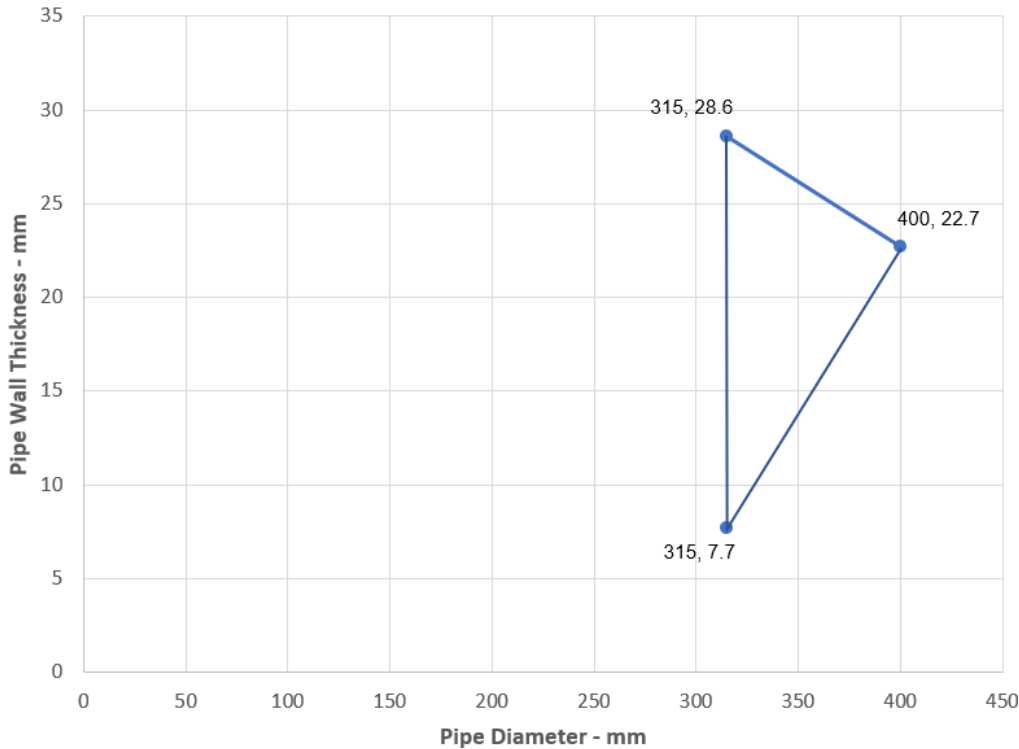

Figure 30 Intermediate pipe wall thicknesses for PP pipe diameters from 315-400 mm

Table 55 Pipe penetration seal with Protecta EX Mortar

Services	Wrap	Permitted configuration for seal separation	Min. mortar depth and floor thickness	FRL
PE pipes				
Diameter 126 mm, wall thickness 3.9-11.4 mm to diameter 160 mm, wall thickness 14.6 mm*	75 mm × 18 mm (10 × 1.8 layers)	N/A	150 mm	-/240/120 U/U
160 mm diameter / 14.6 mm wall	75 mm × 7.2 mm (4 × 1.8 layers)	1 & 2	150 mm	-/240/120 U/U
Diameter 161 mm, wall thickness 4.9-14.6 mm to diameter 200 mm, wall thickness 6.2-18.2 mm*	75 mm × 10.8 mm (6 × 1.8 layers)	1 & 2	150 mm	-/120/120 C/C
200 mm diameter / 6.2-18.2 mm wall thickness	75 mm × 10.8 mm (6 × 1.8 layers)	1 & 2	120 mm	-/240/240 C/C
Diameter 161 mm, wall thickness 4.9-14.6 mm to diameter 315 mm, wall thickness 9.7-18.7 mm*	75 mm × 18 mm (10 × 1.8 layers)	N/A	150 mm	-/60/60 C/C
Note: *Typical pipe diameters shown, see below graphs in Figure 31 to Figure 33 for intermediate sizes				

PE Pipes 126-160 mm Diameter - E 240 U/U, EI 120 U/U

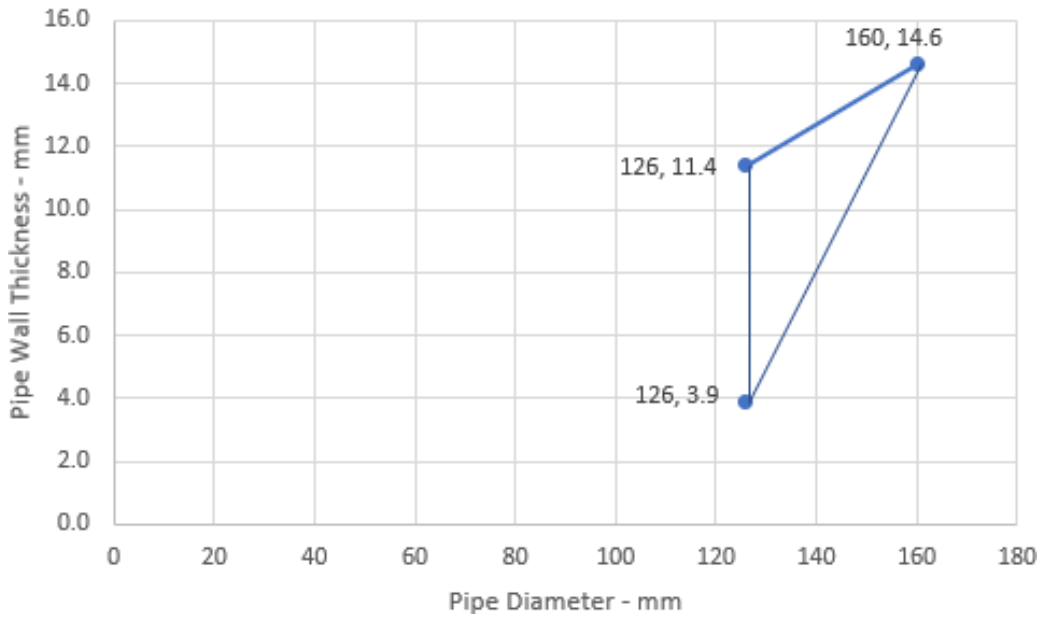

Figure 31 Intermediate pipe wall thicknesses for PE pipe diameters from 126-160 mm

PE Pipes 161-200 mm Diameter - EI 120 - C/C

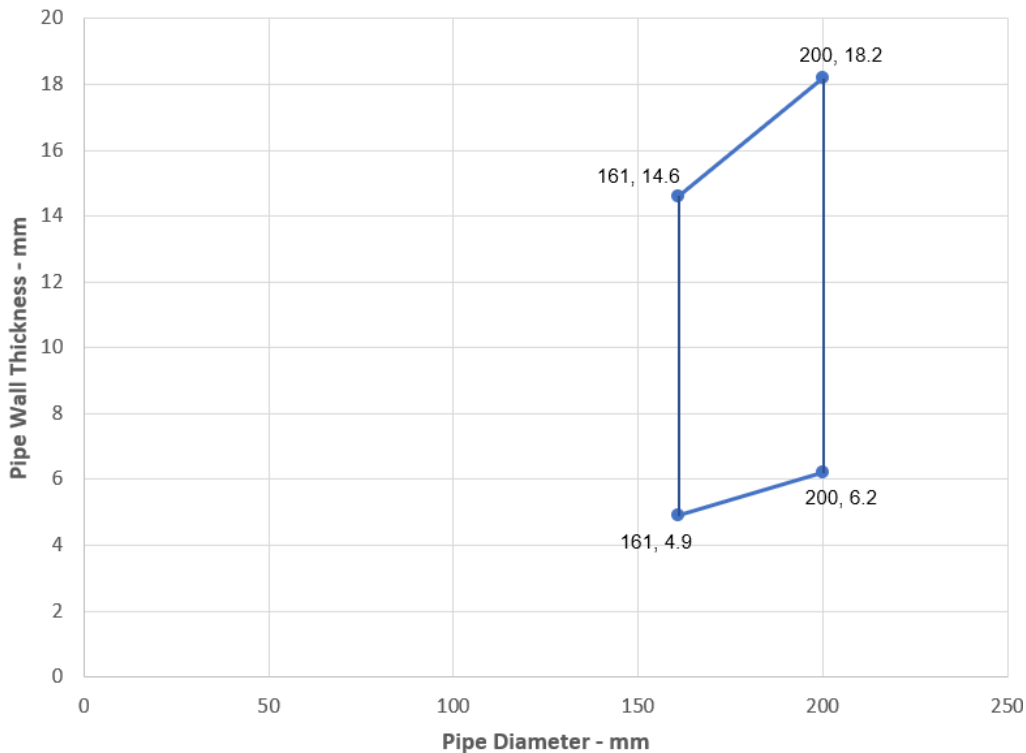

Figure 32 Intermediate pipe wall thicknesses for PE pipe diameters from 161-200 mm

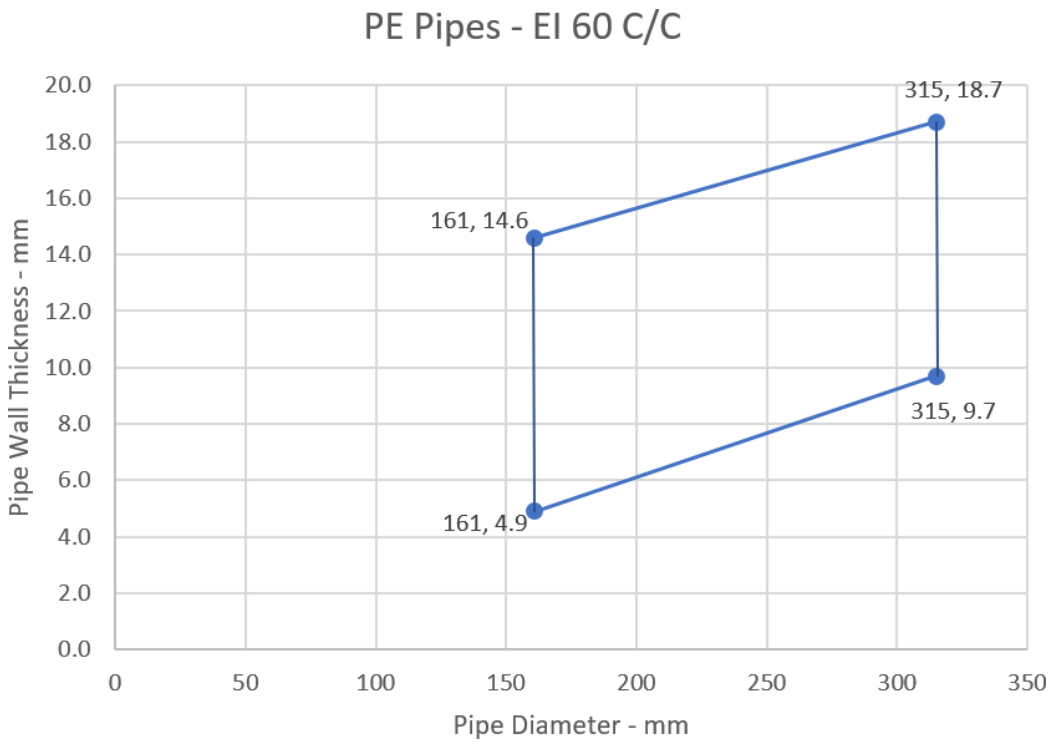
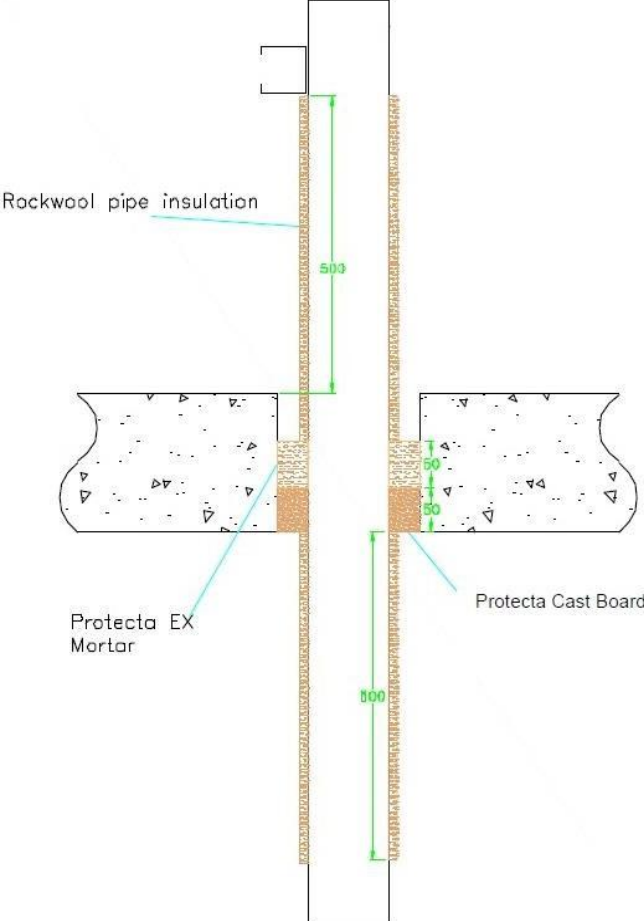
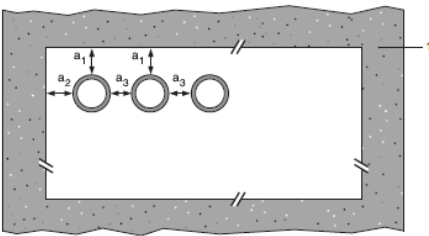
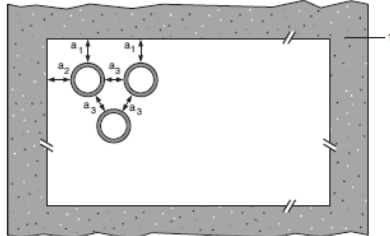

Figure 33 Intermediate pipe wall thicknesses for PE pipe diameters from 161-315 mm

6.4.12 Pipe penetration seal with 50 mm deep Protecta EX Mortar

Table 56 Construction details

<p>Penetration seal: CI (Continuous Interrupted) or LI (Local Interrupted) insulated composite pipes fitted at any position within the aperture (min. separation 10 mm from seal edges), with min. 50 mm Protecta EX Mortar to either surface of the floor or anywhere between, backed with minimum 50 mm stone wool min. 150 kg/m³.</p>	
<p>Construction details:</p> 	
<p>Configuration 1</p> 	<p>Configuration 2</p> 

Penetration seal:

CI (Continuous Interrupted) or LI (Local Interrupted) insulated composite pipes fitted at any position within the aperture (min. separation 10 mm from seal edges), with min. 50 mm Protecta EX Mortar to either surface of the floor or anywhere between, backed with minimum 50 mm stone wool min. 150 kg/m³.

Key:

- 1 Supporting construction
- a1 Pipe / top edge of seal separation
- a2 Pipe / side edge of seal separation
- a3 Pipe / pipe separation

Table 57 Single side penetration seal with pipes

Services	Maximum Aperture	Insulation	FRL
Alupex pipes			
16 mm diameter/2.25 mm wall*	135 mm × 135 mm	500 mm long, minimum 20 mm Stone wool insulation minimum 80 kg/m ³	-/240/240 C/C
16 mm diameter/2.25 mm wall*			-/240/180 C/C
20 mm diameter/2.5 mm wall*			
26 mm diameter/3 mm wall*			
32 mm diameter/3 mm wall*			
40 mm diameter/3.5 mm wall*			
50 mm diameter/4 mm wall*			
63 mm diameter/4.5 mm wall*			
75 mm diameter/4.7 mm wall*			
16 mm diameter/2.25 mm wall*	As section 4.1 dot point 4		-/180/180 C/C
20 mm diameter/2.5 mm wall*			
26 mm diameter/3 mm wall*			
32 mm diameter/3 mm wall*			
40 mm diameter/3.5 mm wall*			
50 mm diameter/4 mm wall*			
63 mm diameter/4.5 mm wall*			
75 mm diameter/4.7 mm wall*			
<p>Note:</p> <p>*Typical pipe diameters shown, see below graph in Figure 34 for intermediate sizes</p>			

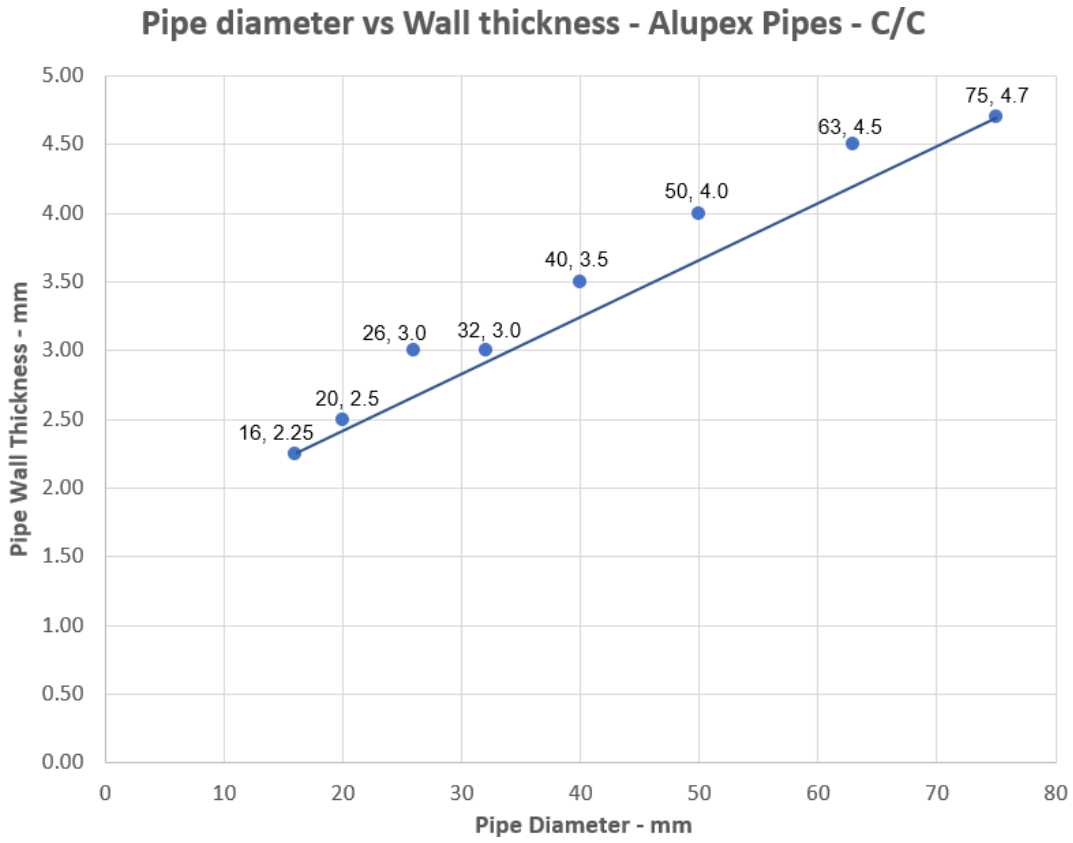

Figure 34 Intermediate pipe wall thicknesses for Alupex pipe diameters

6.4.13 Pipe penetration seal with 50 mm deep Protecta EX Mortar

Table 58 Construction details

<p>Penetration seal: CS (Continuous Sustained) insulated metal pipes, uninsulated metal pipes and composite with Protecta EX Mortar, to either side of the floor, backed with stone wool board min. 150 kg/m³. Minimum separation from pipes to seal edges of 30 mm (a1 & a2). Maximum seal size as section 4.1 dot point 4.</p>	
<p>Construction details:</p>	
<p>Configuration 1</p>	<p>Configuration 2</p>
<p>Key: 1 Supporting construction a1 Pipe / top edge of seal separation a2 Pipe / side edge of seal separation a3 Pipe / pipe separation</p>	

Table 59 Single side penetration seal with pipes

Services	Maximum Aperture	Insulation	FRL
Copper or steel pipes			
12 -54 mm diameter/0.7-14.2 mm wall*	As section 4.1 dot point 4	20-80 mm Stone wool insulation minimum 80 kg/m ³	-/180/120 C/C
6 mm diameter/0.7-3.0 mm wall*		None	-/180/120 C/C
7-15 mm diameter/0.7-7.5 mm wall*			-/180/30 C/C
16-54mm diameter/1.2-14.2 mm wall*			-/180/- C/C
Steel pipes			
4-16 mm diameter/1.0-8.0 mm wall*	None	None	-/180/180 C/U
17-324 mm diameter/6.35-14.2 mm wall*			-/180/- C/U
Alupex pipes			
16-20 mm diameter/2.0 mm wall	None	None	-/180/180 C/C
75mm diameter/4.6 mm wall			-/180/30 C/C
16 mm diameter/2.25 mm wall		20 mm glass- or stone wool insulation minimum 75 kg/m ³	-/180/180 C/C
16-75 mm diameter/2.25-4.6 wall*		25-50 mm glass- or stone wool insulation minimum 75 kg/m ³	-/120/120 C/C
Note: *Typical pipe diameters shown, see below graphs in Figure 35 to Figure 39 for intermediate sizes			

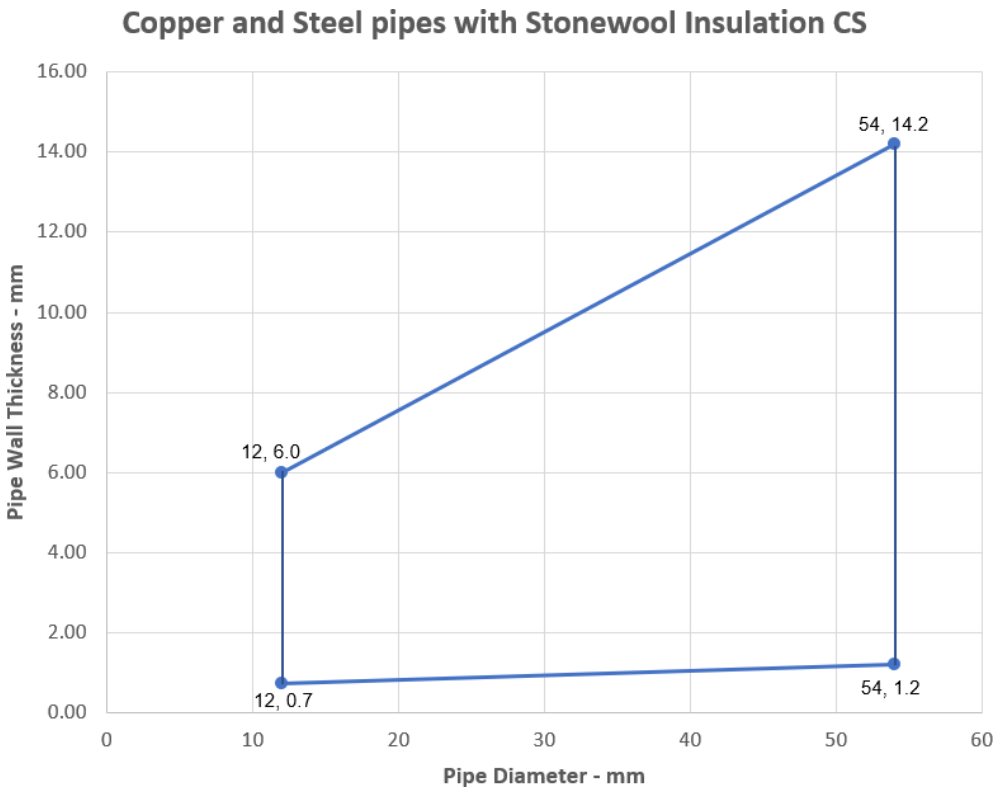

Figure 35 Intermediate pipe wall thicknesses for Copper or steel pipe diameters (with CS insulation)

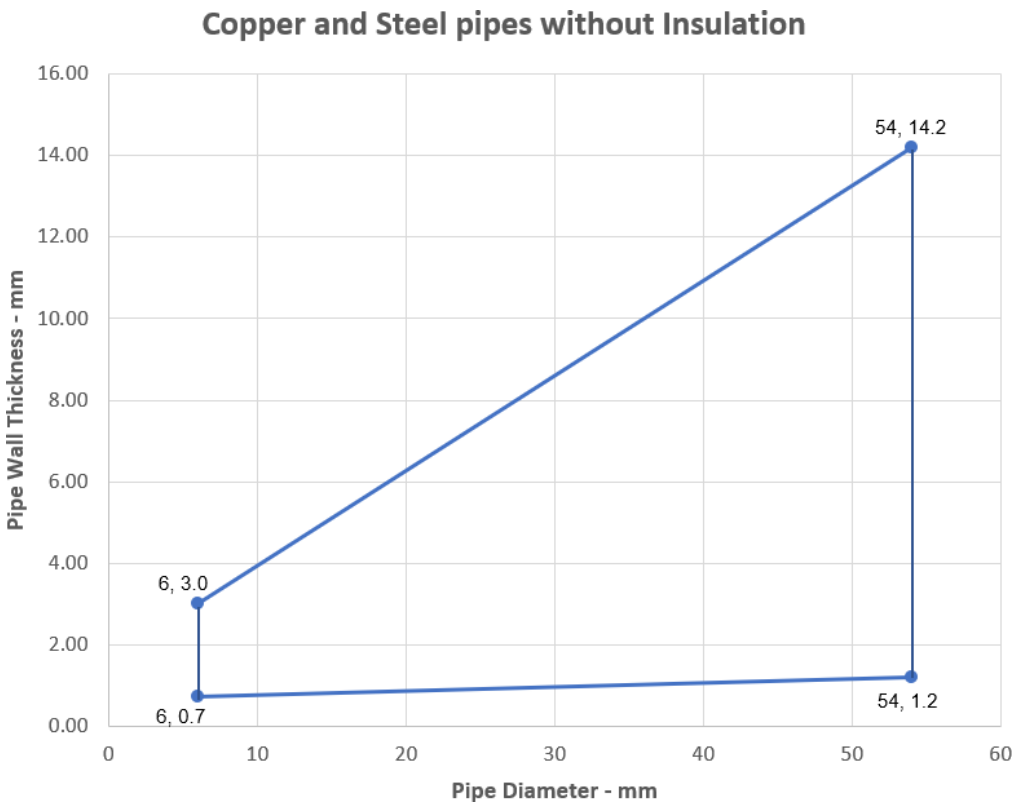

Figure 36 Intermediate pipe wall thicknesses for Copper or steel pipe diameters without insulation

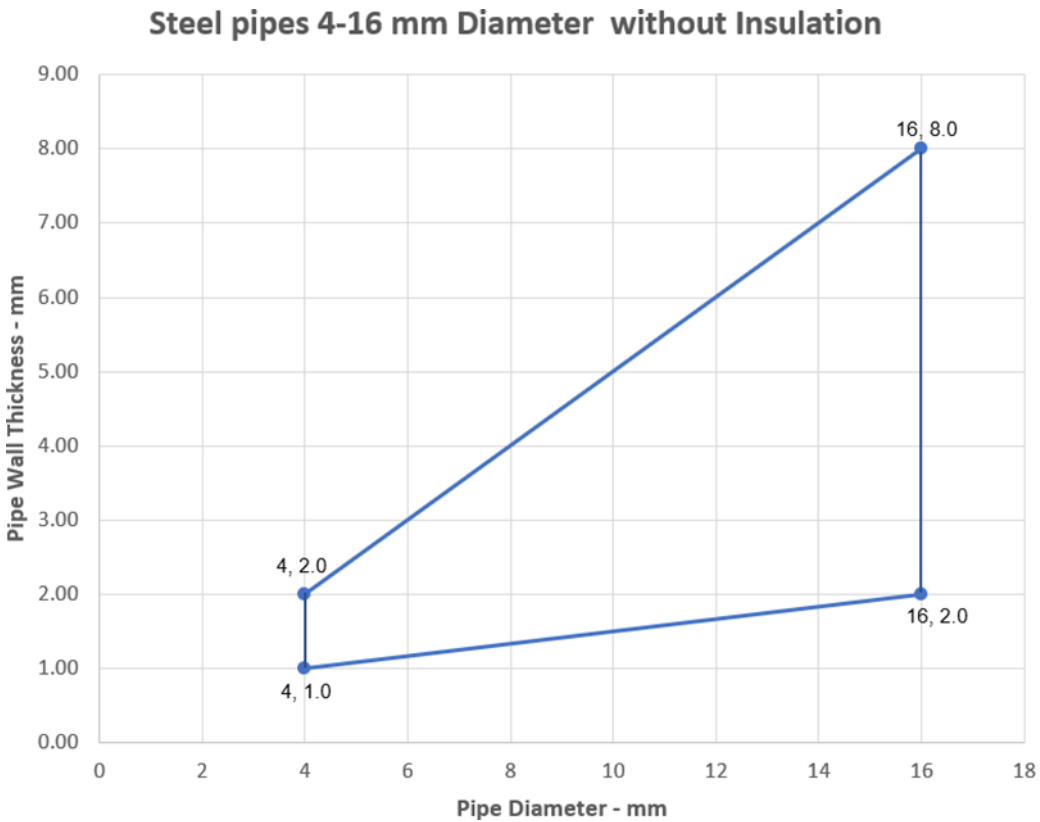

Figure 37 Intermediate pipe wall thicknesses for steel pipe diameters 4-16 mm without insulation

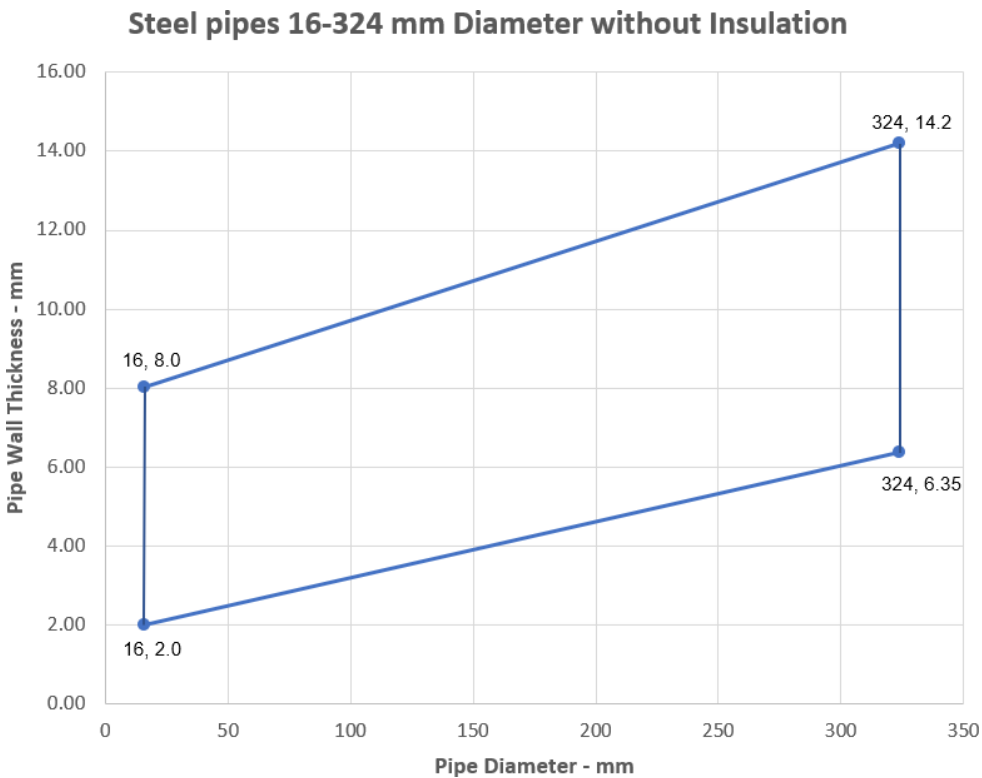

Figure 38 Intermediate pipe wall thicknesses for steel pipe diameters 16-324 mm without insulation

Alupex pipes 16-75 mm Diameter with Glass or Stonewool Insulation CS

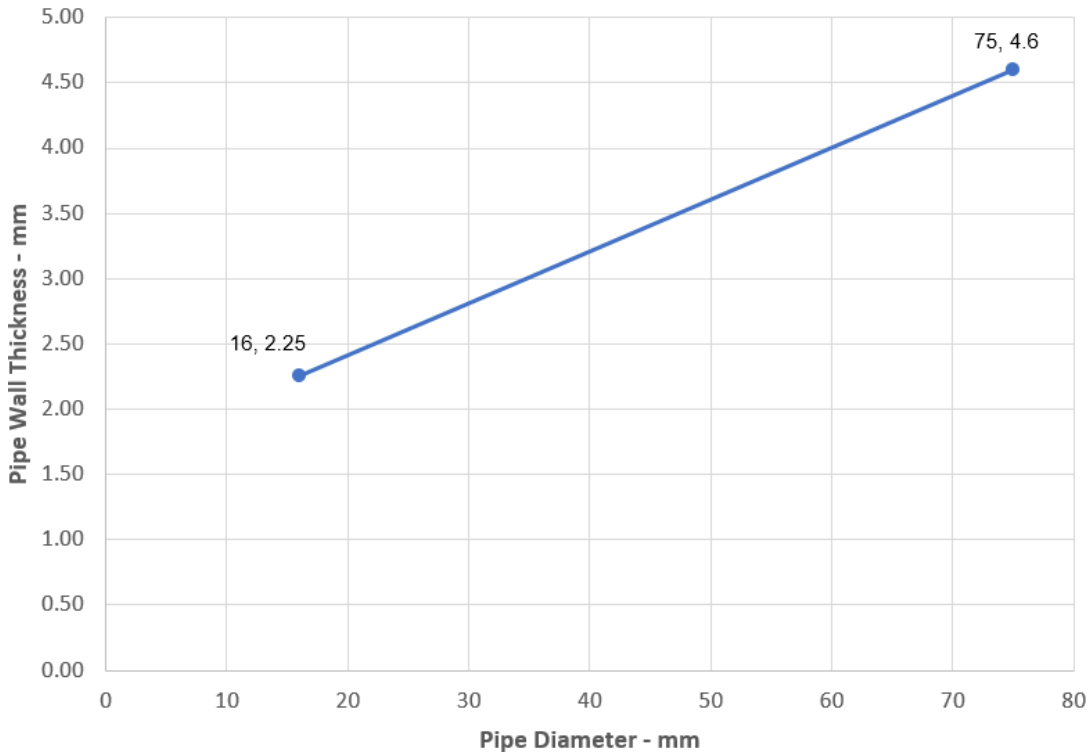

Figure 39 Intermediate pipe wall thicknesses for Alupex pipe diameters 16-75 mm with CS insulation

6.4.14 Pipe penetration seal with 50 mm deep Protecta EX Mortar

Table 60 Construction details

Penetration seal: Plastic pipes fitted at any position within the aperture (min. separation 30 mm from seal edges and 30 mm from other services), with minimum 50 mm Protecta EX Mortar flush with the top of floor, backed with min. 50 mm stone wool min. 150 kg/m ³ .	
Construction details:	
Configuration 1	Configuration 2
Key: 1 Supporting construction a1 Pipe / top edge of seal separation a2 Pipe / side edge of seal separation a3 Pipe / pipe separation	

Table 61 Single sided penetration seal with pipes

Services	Wrap	Maximum aperture	FRL
40 mm diameter /3 mm wall PP pipes	None	As section 4.1 dot point 4	-/120/120 C/C
40 mm diameter /4 mm wall PE pipes			
110 mm diameter /4.3 mm wall PE pipes	50 mm × 1.8 mm		-/60/60 C/C

6.4.15 Pipe penetration seal with 50 mm deep Protecta EX Mortar

Table 62 Construction details

<p>Penetration seal: Combustible pipes sealed with Protecta EX Mortar, to either side of the floor, backed with stone wool board min. 150 kg/m³. Minimum separation between pipes of 30 mm (a3) and from seal edges 30 mm (a1 & a2). Maximum seal size as section 4.1 dot point 4.</p>	
<p>Construction details:</p> 	
<p>Configuration 1</p> 	<p>Configuration 2</p> 
<p>Key: 1 Supporting construction a1 Pipe / top edge of seal separation a2 Pipe / side edge of seal separation a3 Pipe / pipe separation</p>	

Table 63 Single side penetration seal with cables

Services	Seal Depth	Permitted configuration for seal separation	FRL
PVC-U pipes			
Diameter 16 mm, wall thickness 1.6 – 3.4 mm, to diameter 40 mm, wall thickness 1.9-3.0 mm*	Min. 50 mm	1 & 2 between all specified pipes	-/120/120 U/C, C/C
Note: *See below graph in Figure 40 for intermediate sizes			

PVC Pipes - EI 120 - U/C

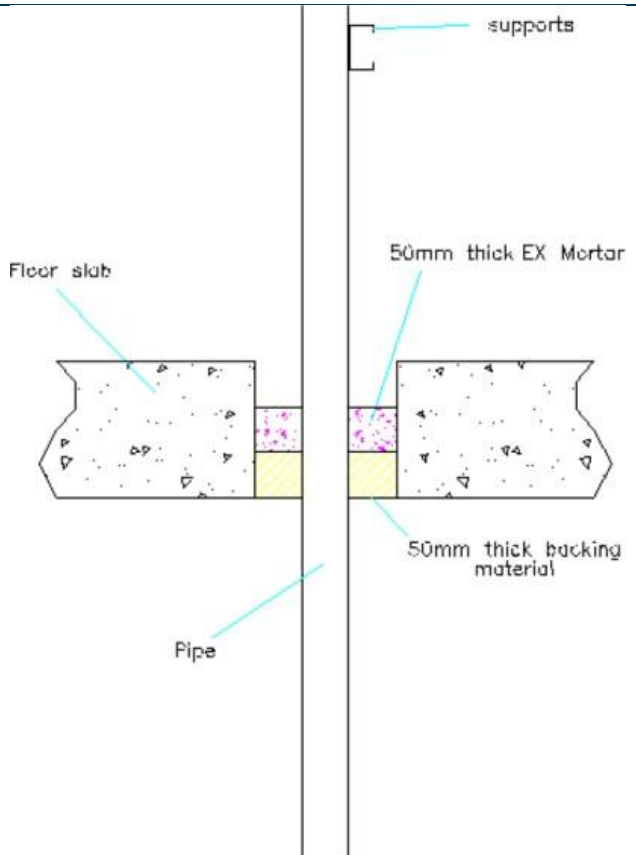
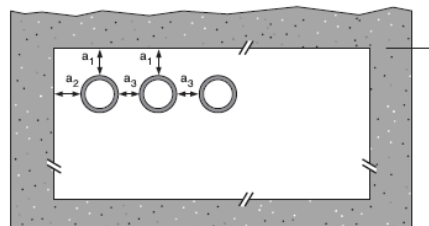
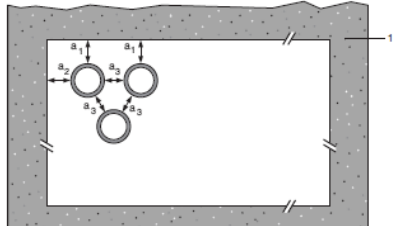
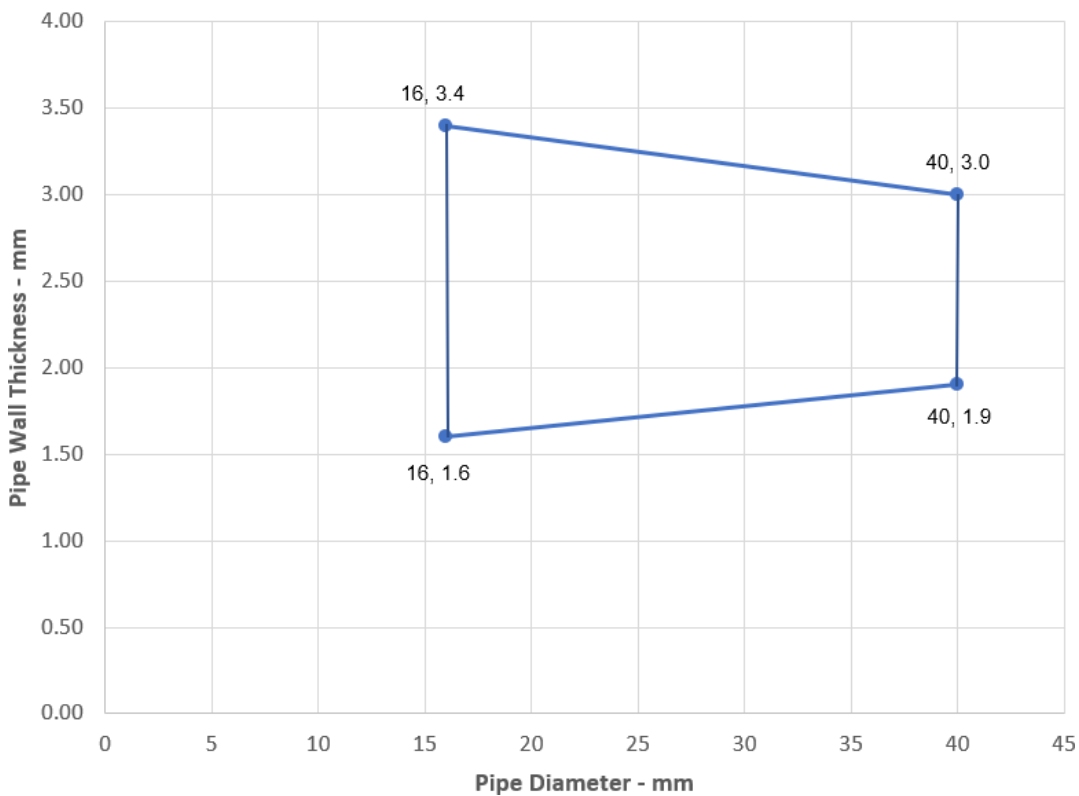

Figure 40 Intermediate pipe wall thicknesses for PVC pipe diameters

6.5 Rigid floor constructions according to section 4.1 dot point 2 with floor thickness of minimum 120 mm

6.5.1 Pipe penetration seal with 120 mm deep Protecta EX Mortar

Table 64 Construction details

Penetration seal:
 CS (Continuous Sustained) insulated plastic pipes fitted at any position within the aperture (min. separation 30 mm from seal edges and 30 mm from other services), with min. 120 mm Protecta EX Mortar to either surface of the floor or anywhere between. Protecta FR Pipes Wraps are required to be fitted around combustible pipe insulation to the bottom of the seal, as indicated below. Maximum seal size as section 4.1 dot point 4.

Construction details:

Table 65 Single sided penetration seal with pipes

Services	Outer diameter including insulation	Pipe wrap	Pipe insulation	FRL
PE pipes				
Maximum 160 mm diameter pipe*	Maximum 68 mm diameter	50 mm × 3.6 mm (2 × 1.8 layers)	9-50 mm Elastomeric insulation minimum class B-s3,d0 or foil faced phenolic foam insulation	-/240/240 C/C
	Maximum 178 mm diameter	75 mm × 10.8 mm (6 × 1.8 layers)		
	Maximum 260 mm diameter	75 mm × 18.0 mm (10 × 1.8 layers)		-/120/120 C/C
PP pipes				
Maximum 160 mm diameter pipe*	Maximum 68 mm diameter	50 mm × 3.6 mm (2 × 1.8 layers)	9-50 mm Elastomeric insulation minimum class B-s3,d0 or foil faced phenolic foam insulation	-/240/180 C/C
	Maximum 178 mm diameter	75 mm × 10.8 mm (6 × 1.8 layers)		-/240/240 C/C
	Maximum 260 mm diameter	75 mm × 18.0 mm (10 × 1.8 layers)		-/120/120 C/C

Note:

*See below graphs in Figure 41 and Figure 42 for interpolation pipe sizes

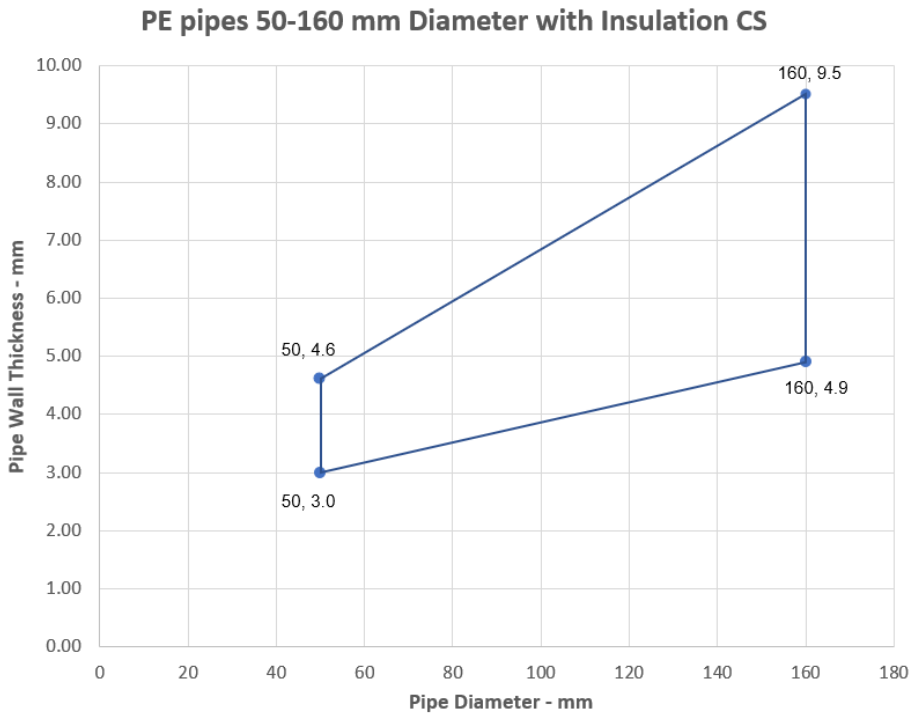

Figure 41 Intermediate pipe wall thicknesses for typical PE pipe with 50 – 160 mm diameters (Continuous sustained insulation)

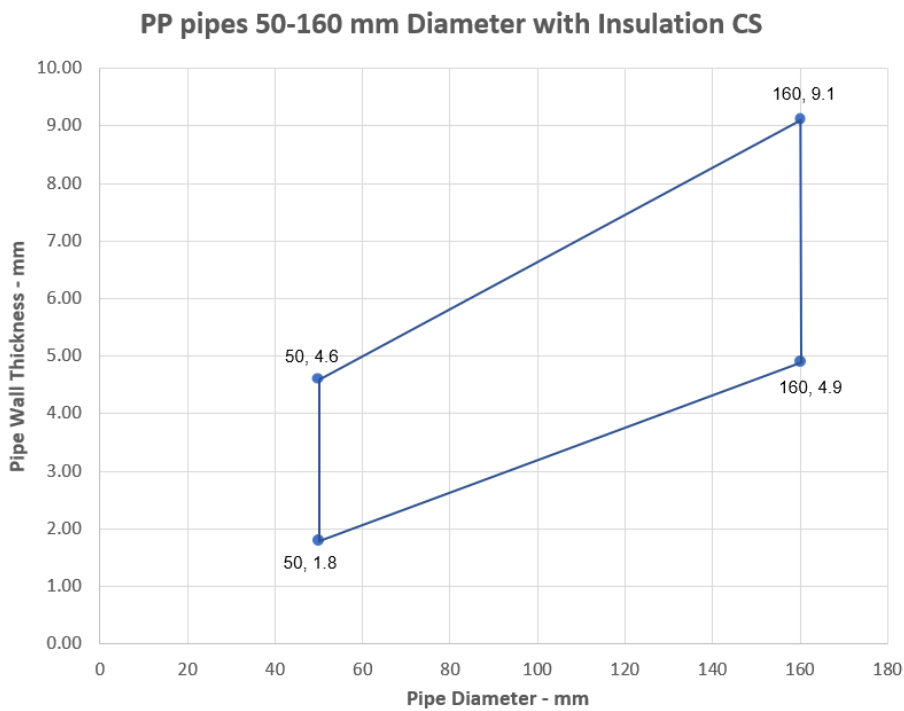

Figure 42 Intermediate pipe wall thicknesses for typical PP pipe with 50 – 160 mm diameters (Continuous sustained insulation)

6.6 Rigid floor constructions according to section 4.1 dot point 2 with floor thickness of minimum 150 mm

6.6.1 Pipe penetration seal with 150 mm deep Protecta EX Mortar

Table 66 Construction details

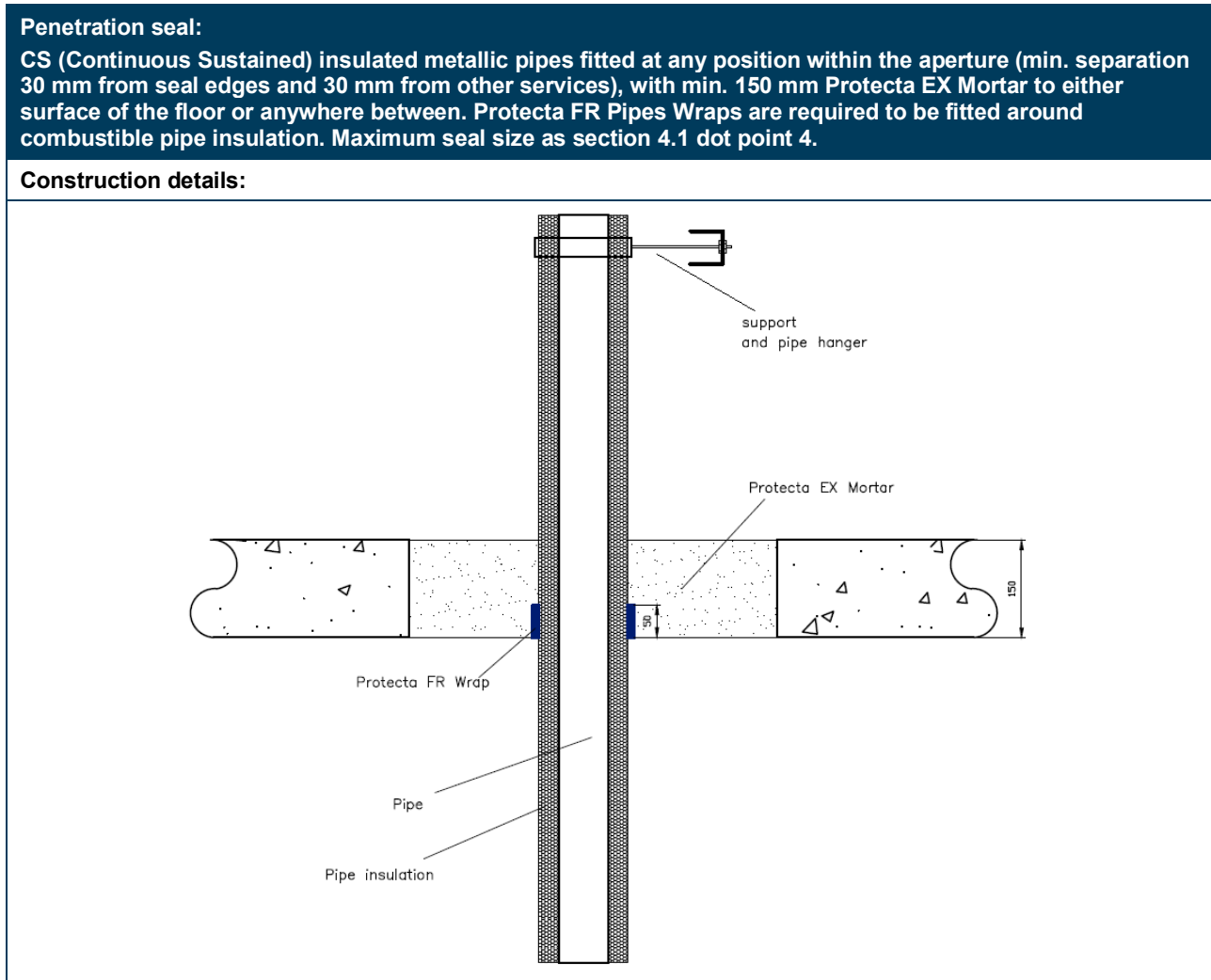

Table 67 Single side penetration seal with pipes

Services	Wrap	Insulation	FRL
Mild or stainless steel pipes			
12 mm diameter/ 1.0 mm wall	1 off 50 mm × 1.8 mm Protecta FR Pipe Wrap, fitted at soffit	9 mm PE foam insulation	-/180/180 C/U
Maximum 76 mm diameter/ 1.5-14.2 mm wall*	2 off 50 mm × 1.8 mm Protecta FR Pipe Wrap, fitted at soffit	9-30 mm PE foam insulation	-/180/60 C/U
Note: *See below graph in Figure 43 for intermediate sizes.			

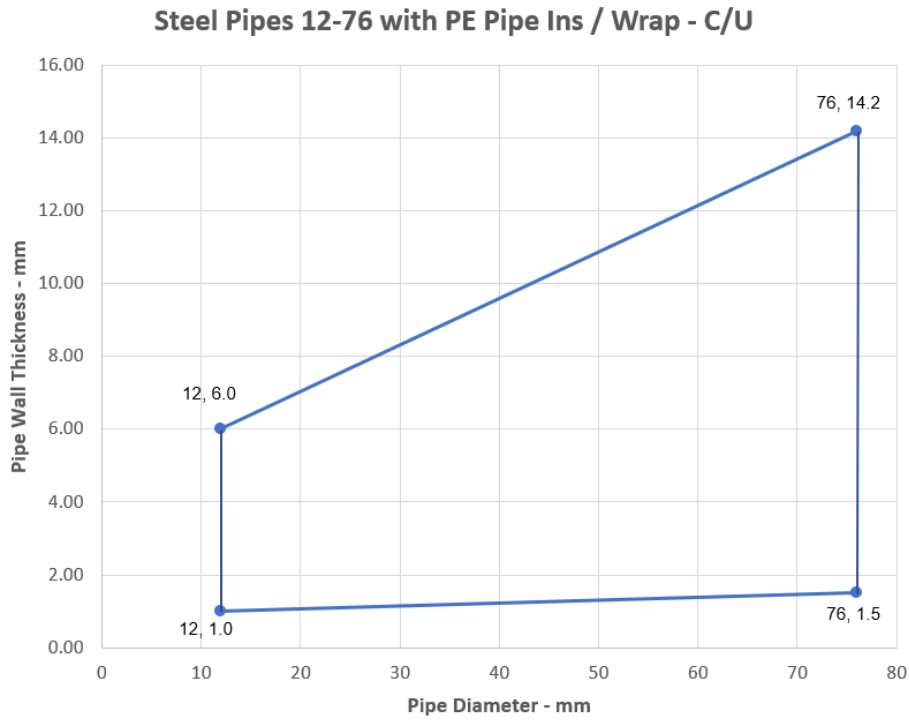

Figure 43 Intermediate pipe wall thicknesses for typical steel pipes with PE pipe insulation (C/U pipe end conditions)

6.6.2 Pipe penetration seal with 150 mm deep Protecta EX Mortar

Table 68 Construction details

Penetration seal:
 Plastic pipes fitted at any position within the aperture (min. separation 30 mm from seal edges and from other services), with 150 mm Protecta EX Mortar to either surface of the floor or anywhere between. Protecta FR Pipe Wraps are required to be fitted to the bottom of the seal, as indicated below. Maximum seal size as section 4.1 dot point 4.

Construction details:

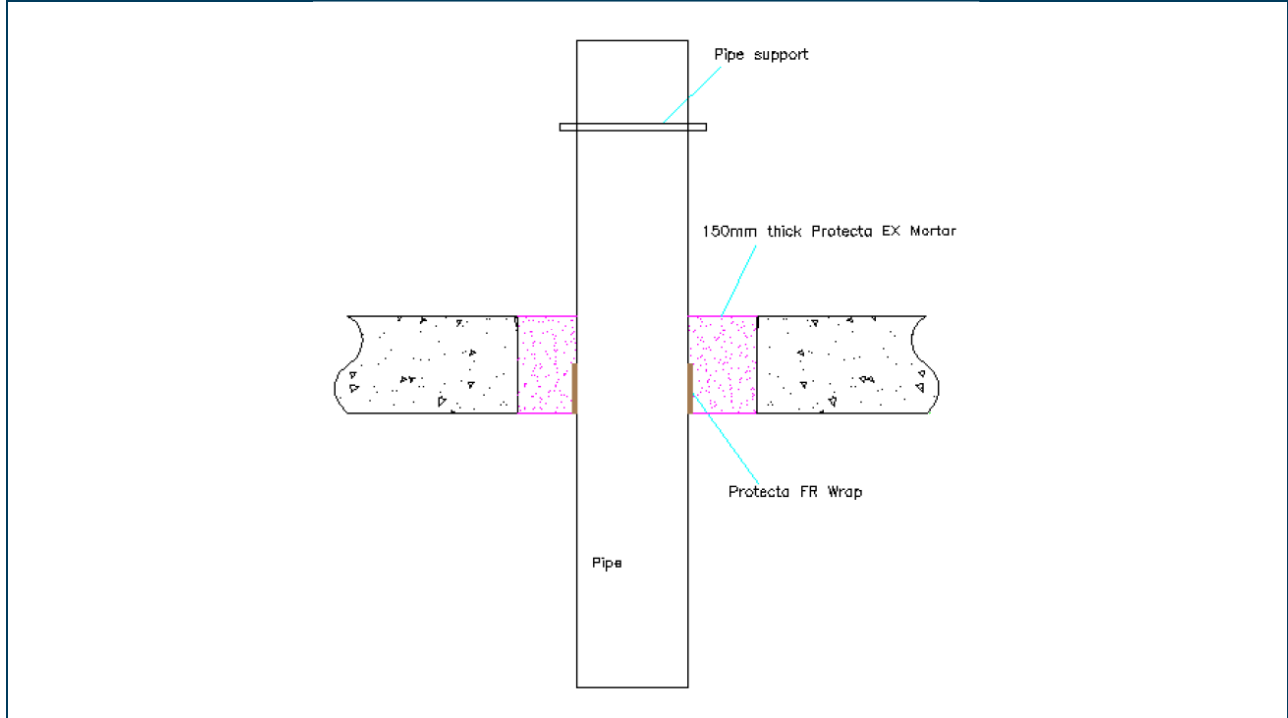

Configuration 1

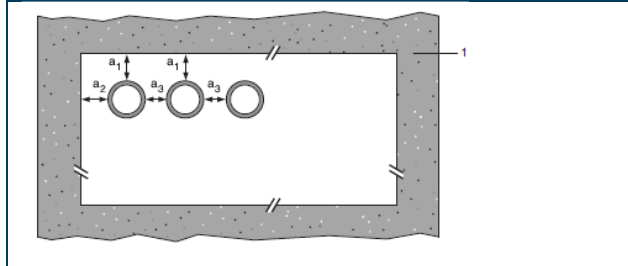

Configuration 2

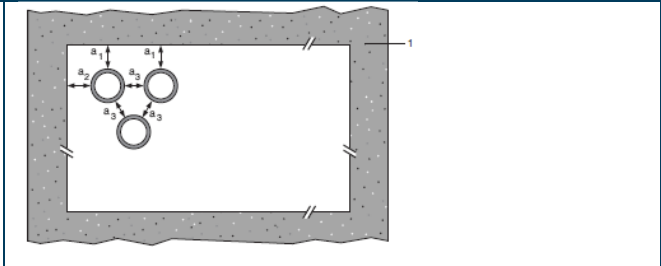

Key:
 1 Supporting construction
 a1 Pipe / top edge of seal separation
 a2 Pipe / side edge of seal separation
 a3 Pipe / pipe separation

Table 69 Pipe penetration seal with 150 mm deep Protecta EX Mortar

Services	Wrap	Permitted configuration for seal separation	FRL
PVC-U pipes			
Up to 40 mm diameter/1.8-3.7 mm wall*	50 mm × 1.8 mm	1 & 2	-/120/120 U/U
Up to 125 mm diameter / 4.8-7.4 mm wall*	50 mm × 7.2 mm		-/60/60 U/U
Up to 160 mm diameter/9.5 mm wall*	75 mm × 7.2 mm		-/120/30 U/U
PP pipes			
Up to 40 mm diameter/1.8-5.5 mm wall*	50 mm × 1.8 mm	1 & 2	-/120/120 U/U
Up to 125 mm diameter / 11.4 mm wall*	50 mm × 7.2 mm		-/240/240 U/U
Up to 160 mm diameter/14.6 mm wall*	75 mm × 7.2 mm		-/240/240 U/U
PE pipes			
Up to 40 mm diameter/2.4-3.7 mm wall*	50 mm × 1.8 mm	1 & 2	-/240/240 U/U
Up to 110 mm diameter/3.4-10 mm wall*	75 mm × 5.4 mm		-/240/240 U/U
Up to 125 mm diameter / 11.4 mm wall*	50 mm × 7.2 mm		-/240/240 U/U
Up to 160 mm diameter/4.9-14.6 mm wall*	75 mm × 7.2 mm		-/120/120 U/U
Note: *Typical pipe diameters shown, see below graphs in Figure 44 to Figure 46 for intermediate sizes			

PVC-U Pipes - E 60 U/U, EI 30 U/U

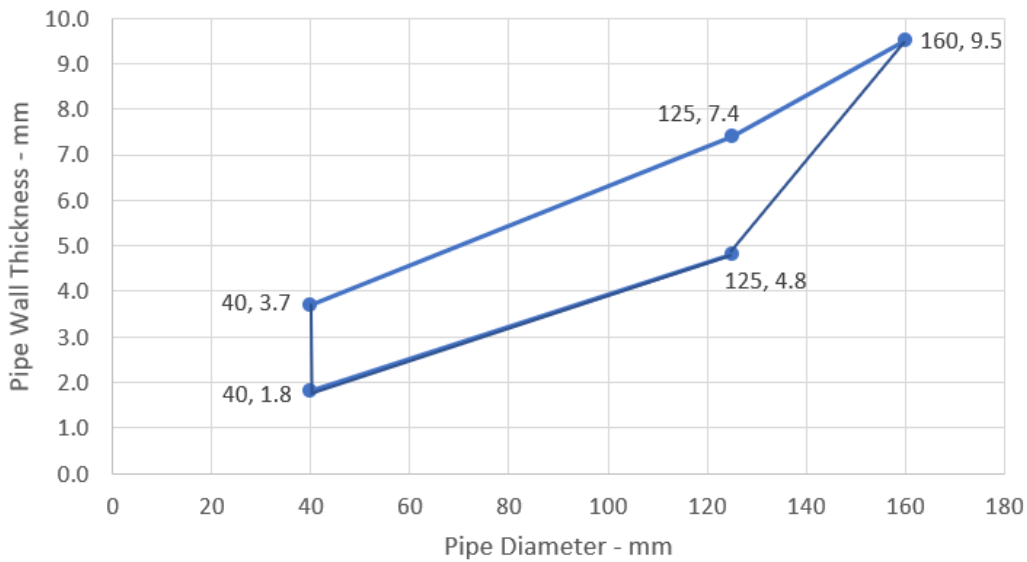

Figure 44 Intermediate pipe wall thicknesses for typical PVC-U pipes

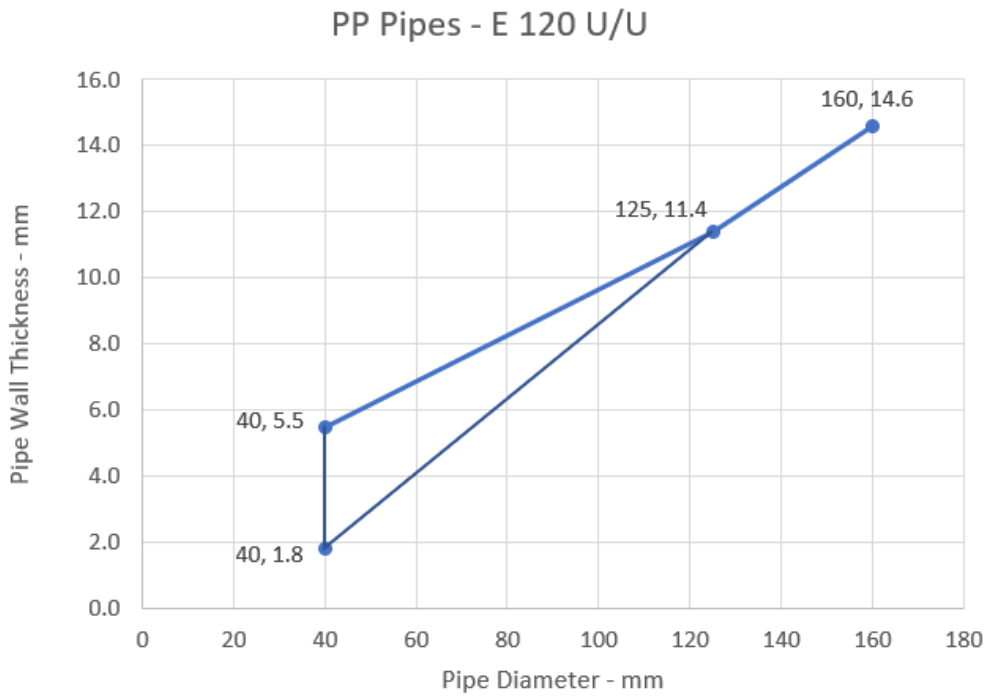

Figure 45 Intermediate pipe wall thicknesses for typical PP pipes

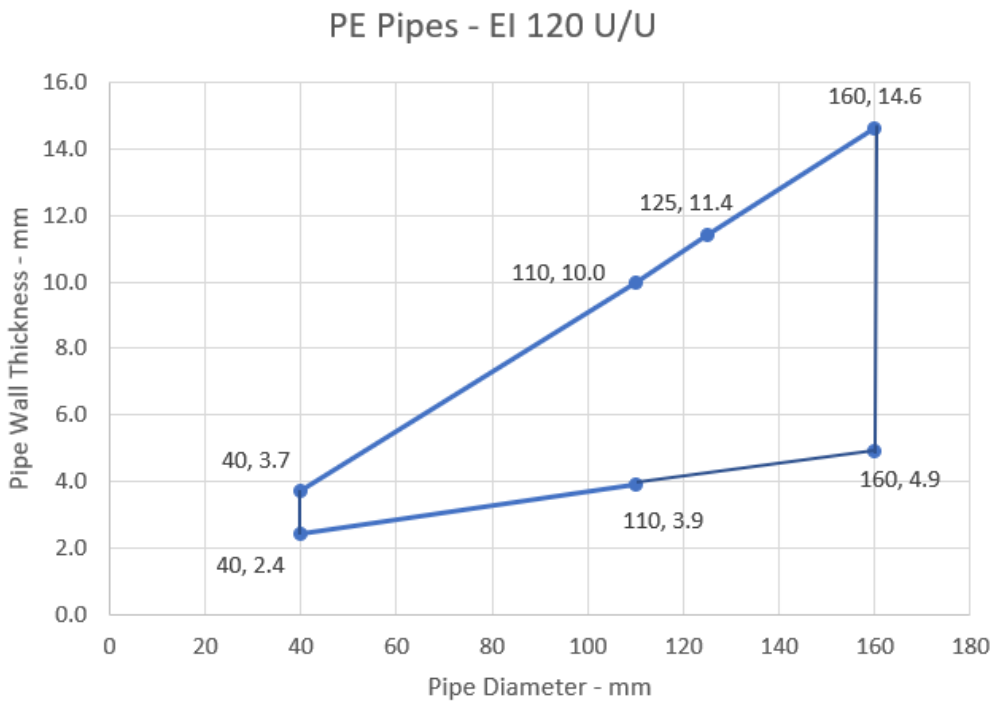

Figure 46 Intermediate pipe wall thicknesses for typical PE pipes

6.6.3 Cable penetration seal with 150 mm deep Protecta EX Mortar

Table 70 Construction details

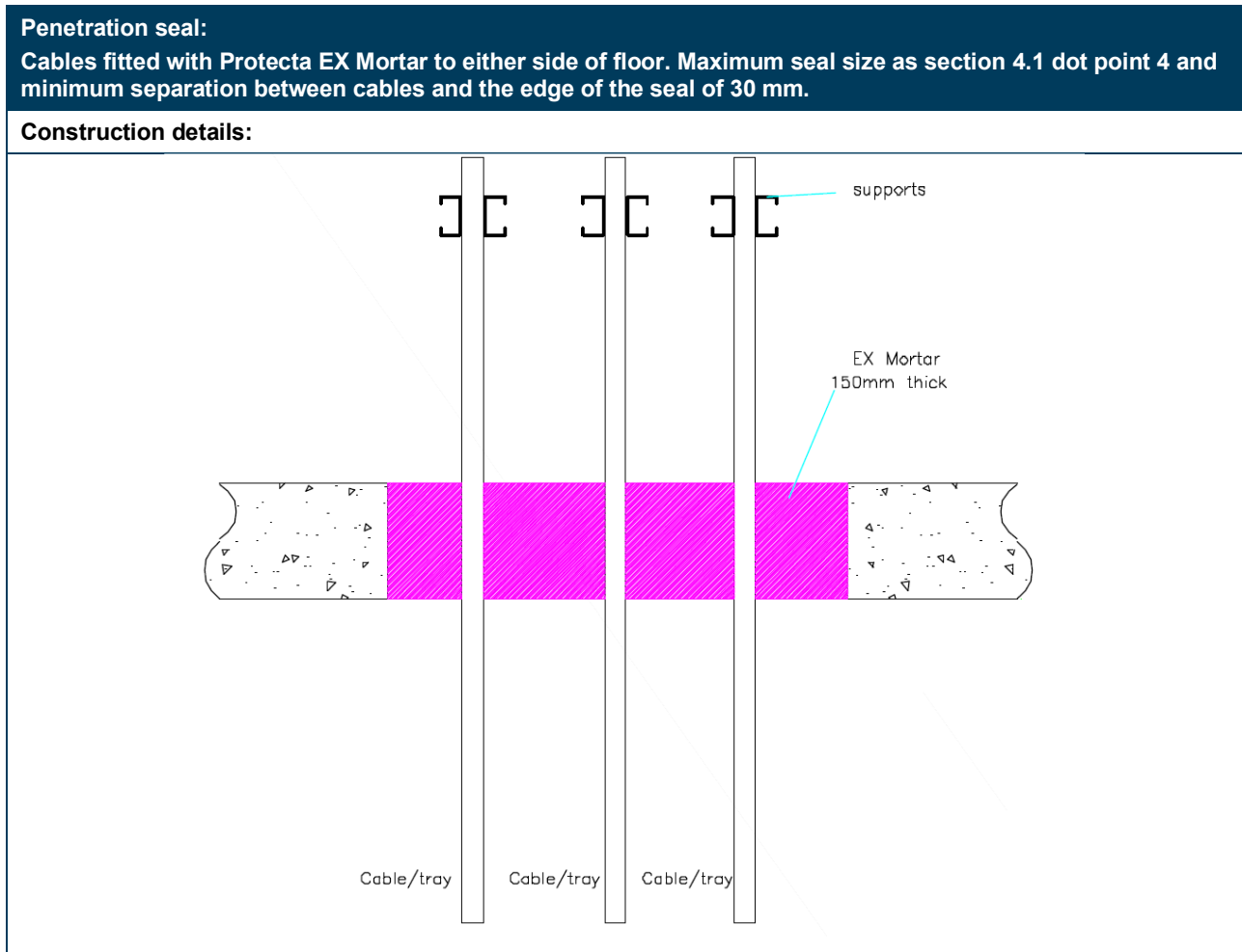

Table 71 Single side penetration seal with cables

Services	Mortar depth	Backing	Insulation	FRL
Blank seals	Min. 150 mm	None	None	-/240/240
Electric cables up to 21 mm diameter, single or in a bundle.				-/240/120
Steel cable trays and ladders up to 500 mm wide				
Electric cables 22-50 mm diameter, single or in a bundle.				-/240/90
Electric cables 51-80 mm diameter, single or in a bundle.				-/90/60
Unsheathed wire up to 24 mm diameter				-/120/120

6.7 Flexible and rigid wall constructions according to section 4.1 dot point 2 with wall thickness of minimum 100 mm

6.7.1 Cable penetration seal with 25 mm deep Protecta EX Mortar to both faces backed with 50 mm mineral fibre board

Table 72 Construction details

Penetration seal:
 Cables fitted at any position within the aperture (min. separation 25 mm from seal edges), with min. 25 mm Protecta EX Mortar to both sides of the wall, backed with min. 1 × 50 mm or 2 × 25 mm stone wool board min. 150 kg/m³.

Construction details:

Table 73 Double side penetration seal with cables

Services	Maximum aperture	FRL
None (blank)	As section section 4.1 dot point 4.	-/120/120
Single electrical cables up to Ø 21 mm (min.100 separation from other services)		-/120/90
Electrical cables up to Ø 80 mm (single, bundled and on trays)		-/120/60
Steel cable trays & ladders		
Steel conduits up to Ø 16 mm		-/120/60 C/U
Copper conduits up to Ø 16 mm		-/120/45 C/U
Unsheathed wires up to Ø 24 mm		-/120/45
PVC conduits up to Ø 16 mm		-/120/120 C/U, C/C

6.7.2 Pipe penetration seal with 25 mm deep Protecta EX Mortar to both faces backed with 50 mm mineral fibre board

Table 74 Construction details

<p>Penetration seal: CS (Continuous Sustained) insulated metallic pipes fitted at any position within the aperture (min. separation 30 mm from seal edges), with min. 25 mm Protecta EX Mortar to both sides of the wall, backed with min. 1 × 50 mm or 2 × 25 mm stone wool board min. 150 kg/m³ or min. 50 mm Protecta EX Mortar to both sides of the wall without backing*. Protecta FR Pipe wraps are required to be fitted to both faces of the seal.</p>
<p>Construction details:</p>  <p>The diagram shows a vertical steel pipe passing through a horizontal partition assembly. The pipe is surrounded by mineral wool insulation. The partition assembly consists of a steel pipe, mortar, and pipe wraps. Labels include: MINERAL WOOL, STEEL PIPE, MORTAR, PIPE WRAPS, and PARTITION ASSEMBLY.</p>
<p>Note: *Maximum seal size as section 4.1 dot point 4.</p>

Table 75 Double side penetration seal with pipes

Services	Wrap	Insulation	FRL
Mild or stainless steel pipes			
40 mm diameter/1-14.2 mm wall	2 off 50 mm × 1.8 mm Protecta FR Pipe Wrap, one fitted flush to each face of seal	13 mm Elastomeric insulation minimum class B-s3,d0 or PE Foam insulation	-/120/120 C/U
40 mm diameter/1-14.2 mm wall*			-/120/60 C/U
50 mm diameter/1.3-14.2 mm wall*			
60 mm diameter/1.6-14.2 mm wall*			
75 mm diameter/2-14.2 mm wall*			
90 mm diameter/2.4-14.2 mm wall*			
100 mm diameter/2.7-14.2 mm wall*			
115 mm diameter/3.1-14.2 mm wall*			
140 mm diameter/3.8-14.2 mm wall*			
165 mm diameter/ 4.5-14.2 mm wall*			
Note: *Typical pipe diameters shown, see below graph in Figure 47 for intermediate sizes			

Pipe diameter vs Wall thickness

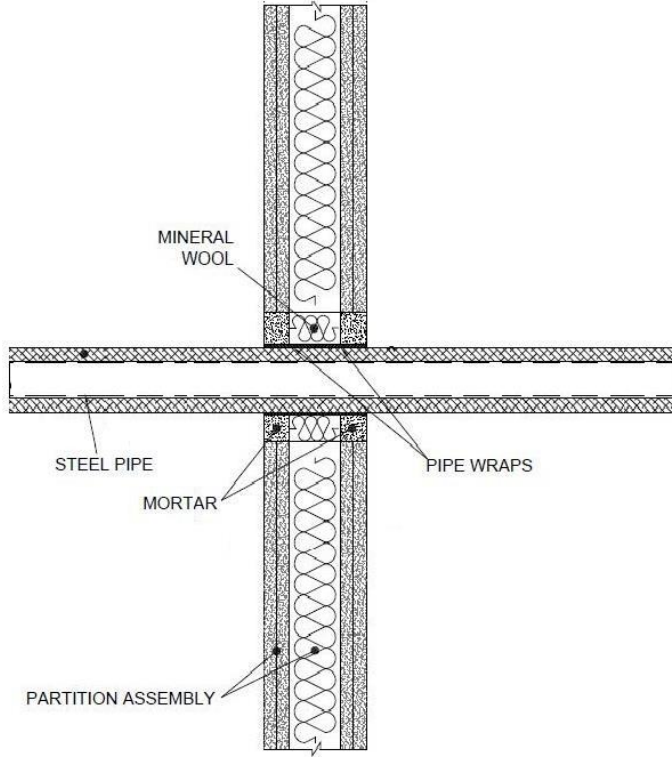
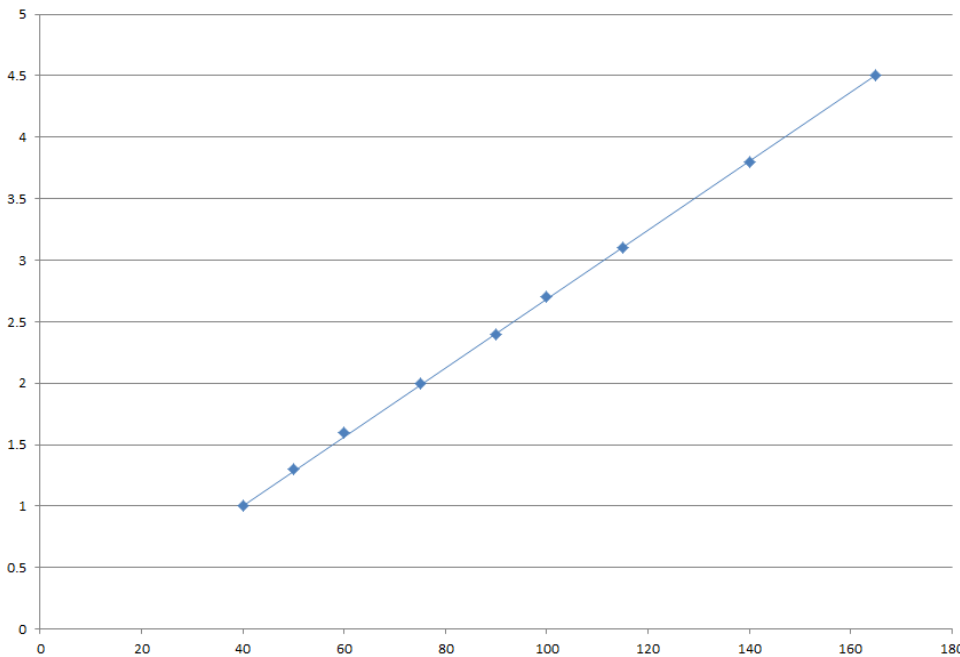

Figure 47 Intermediate pipe wall thicknesses for typical mild or stainless steel pipes

6.7.3 Pipe penetration seal with 25 mm deep Protecta EX Mortar to both faces backed with 50 mm mineral fibre board

Table 76 Construction details

<p>Penetration seal: 500 mm (min.)* LI (Local Interrupted) or CI (Continuous Interrupted) insulated metallic (and composite) pipes fitted at any position within the aperture (min. separation 30 mm from seal edges), with min. 25 mm Protecta EX Mortar to both sides of the wall backed with min. 1 × 50 mm or 2 × 25 mm stone wool board min. 150 kg/m³. Maximum seal size as section 4.1 dot point 4.</p>	
<p>Construction details:</p>	
<p>Configuration 1</p>	<p>Configuration 2</p>
<p>Key: 1 Supporting construction a1 Pipe / top edge of seal separation a2 Pipe / side edge of seal separation a3 Pipe / pipe separation</p>	

Table 77 Double side penetration seal with pipes

Services	Insulation	FRL
Copper or steel pipes up to 54 mm diameter/1-14.2 mm wall	Min. 20 mm stone wool min. 80 kg/m ³	-/120/120 C/C
Alupex composite pipe 75 mm diameter/7.5 mm wall	600 mm length of 25 mm Protecta Mineral Fibre BIO	-/60/60 U/U, U/C, C/U, C/C

Table 78 Double side penetration seal with pipes

Services	Insulation, minimum thickness and density	FRL
Mild or stainless steel pipes		
40 mm diameter/1-14.2 mm wall	20 mm stone wool 80 kg/m ³	-/120/120 C/U
40 mm diameter/1-14.2 mm wall*	30 mm stone wool 80 kg/m ³	-/120/90 C/U
50 mm diameter/1.2-14.2 mm wall*		
60 mm diameter/1.4-14.2 mm wall*		
75 mm diameter/1.7-14.2 mm wall*		
90 mm diameter/2-14.2 mm wall*		
100 mm diameter/2.2-14.2 mm wall*		
115 mm diameter/2.5-14.2 mm wall*		
140 mm diameter/3-14.2 mm wall*		
165 mm diameter/3.5-14.2 mm wall*		
180 mm diameter/3.8-14.2 mm wall*		
200 mm diameter/4.2-14.2 mm wall*		
219 mm diameter/4.5-14.2 mm wall*		
Note: *Typical pipe diameters shown, see below graph in Figure 48 for intermediate sizes.		

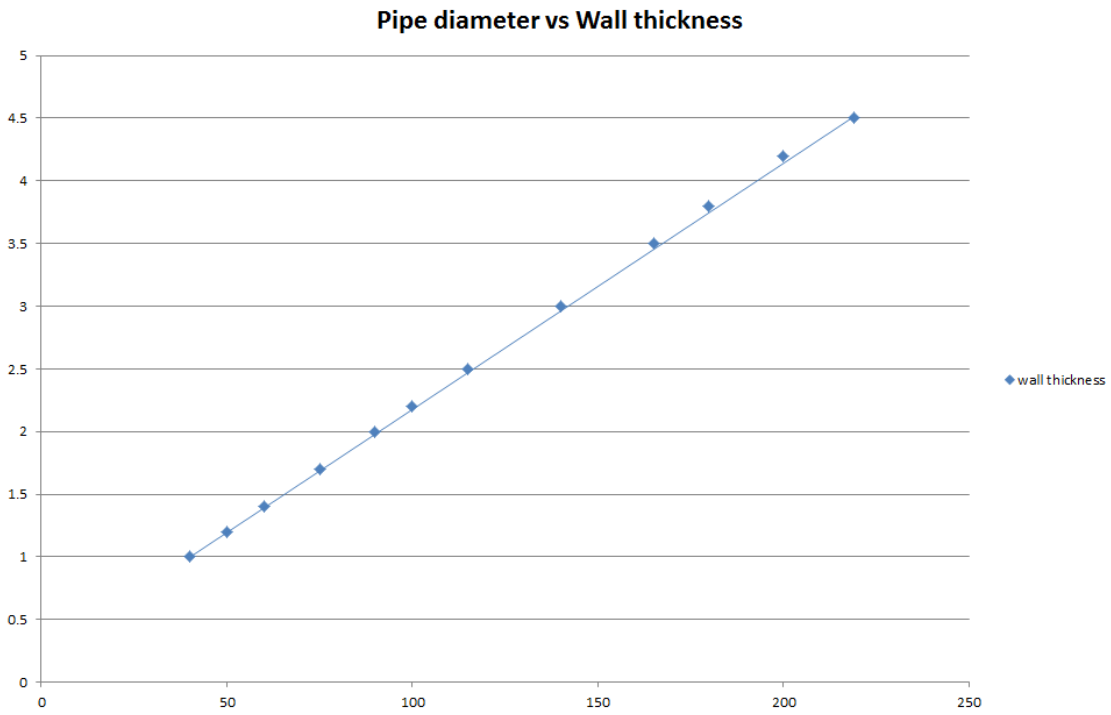

Figure 48 Intermediate pipe wall thicknesses for typical mild or stainless steel pipes

6.7.4 Pipe penetration seal with 25 mm deep Protecta EX Mortar to both faces backed with 50 mm mineral fibre board

Table 79 Construction details

<p>Penetration seal: 500 mm (min.)* LI (Local Interrupted) or CI (Continuous Interrupted) insulated metallic (and composite) pipes fitted at any position within the aperture (min. separation 30 mm from seal edges), with min. 25 mm Protecta EX Mortar to both sides of the wall backed with min. 1 × 50 mm or 2 × 25 mm stone wool board minimum 150 kg/m³. Maximum seal size as section 4.1 dot point 4.</p>	
<p>Construction details:</p>	
<p>Configuration 1</p>	<p>Configuration 2</p>
<p>Key: 1 Supporting construction a1 Pipe / top edge of seal separation a2 Pipe / side edge of seal separation a3 Pipe / pipe separation</p>	

Table 80 Double side penetration seal with pipes

Services	Insulation	FRL
Alupex pipes		
16 mm diameter/2.25 mm wall	Minimum 20 mm stone wool, minimum 80 kg/m ³	-/120/120 C/C
20 mm diameter/2.5 mm wall		
26 mm diameter/3 mm wall		
32 mm diameter/3 mm wall		
40 mm diameter/3.5 mm wall		
50 mm diameter/4 mm wall		
63 mm diameter/4.5 mm wall		
75 mm diameter/4.7 mm wall		
Note: *Typical pipe diameters shown, see below graph in Figure 49 for intermediate sizes.		

Pipe diameter vs Wall thickness - Alupex Pipes with Insulation LI

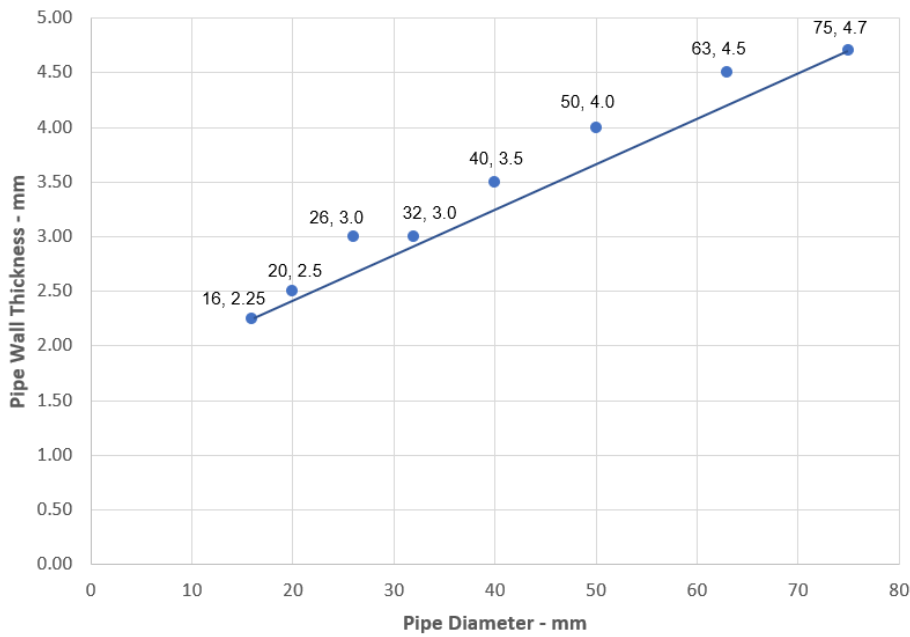

Figure 49 Intermediate pipe wall thicknesses for typical Alupex pipes

6.7.5 Pipe penetration seal with 25 mm deep Protecta EX Mortar to both faces backed with 50 mm mineral fibre board

Table 81 Construction details

<p>Penetration seal: CS (Continuous Sustained) insulated metallic and composite pipes fitted at any position within the aperture (min. separation 25 mm from seal edges), with min. 25 mm Protecta EX Mortar to both sides of the wall, backed with min. 25 mm stone wool min. 150 kg/m³. Protecta FR Pipe wraps are required to be fitted to both faces of the seal. Maximum seal size as section 4.1 dot point 4.</p>	
<p>Construction details:</p>	
<p>Configuration 1</p>	<p>Configuration 2</p>
<p>Key: 1 Supporting construction a1 Pipe / top edge of seal separation a2 Pipe / side edge of seal separation a3 Pipe / pipe separation</p>	

Table 82 Double side penetration seal with pipes

Services	Wrap	Insulation	FRL
Copper and steel pipes			
12-54 mm diameter/1-1.2 mm wall	50 mm × 3.6 mm Protecta FR Pipe Wrap fitted to both sides of the seal	9-25 mm Elastomeric insulation minimum class B-s3, d0 or PE Foam insulation	-/120/120 C/C
Alupex pipes			
16 mm diameter/2.25 mm wall	50 mm × 3.6 mm Protecta FR Pipe Wrap fitted to both sides of the seal	9-25 mm Elastomeric insulation minimum class B-s3, d0 or PE Foam insulation	-/120/120 C/C
20 mm diameter/2.5 mm wall			
26 mm diameter/3 mm wall			
32 mm diameter/3 mm wall			
40 mm diameter/3.5 mm wall			
50 mm diameter/4 mm wall			
63 mm diameter/4.5 mm wall			
75 mm diameter/4.7 mm wall			

Pipe diameter vs Wall thickness - Alupex Pipes with Insulation CS

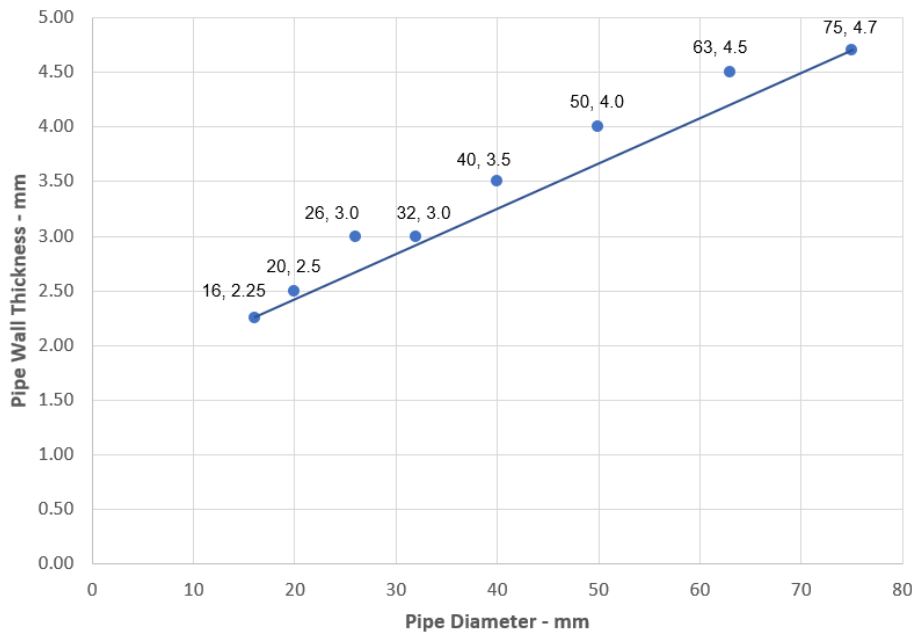

Figure 50 Intermediate pipe wall thicknesses for typical Alupex pipes

6.7.6 Pipe penetration seal with 25 mm deep Protecta EX Mortar to both faces backed with 50 mm mineral fibre board

Table 83 Construction details

<p>Penetration seal: Combustible pipes sealed with Protecta EX Mortar, to both sides of the wall, backed with stone wool board min. 140 kg/m³. Minimum separation between pipes of 30 mm (a₃) and from seal edges 30 mm (a₁ & a₂). Maximum seal size as section 4.1 dot point 4.</p>	
<p>Construction details:</p>	
<p>Configuration 1</p>	<p>Configuration 2</p>
<p>Key: 1 Supporting construction a1 Pipe / top edge of seal separation a2 Pipe / side edge of seal separation a3 Pipe / pipe separation</p>	

Table 84 Double side penetration seal with pipes

Services	Seal Depth	Permitted configuration for seal separation	FRL
PVC-U pipes			
Diameter up to 32 mm, wall thickness 1.6 – 2.4 mm	Min. 25 mm	1 & 2 between all specified pipes	-/120/120 U/C, C/C
PE pipes			
Diameter up to 32 mm, wall thickness 1.8 – 3.0 mm	Min. 25 mm	1 & 2 between all specified pipes	-/120/120 U/C, C/C
PP pipes			
Diameter up to 32 mm, wall thickness 1.9 – 4.4 mm	Min. 25 mm	1 & 2 between all specified pipes	-/120/120 U/C, C/C

6.7.7 Pipe penetration seal with 25 mm deep Protecta EX Mortar to both faces backed with 50 mm mineral fibre board

Table 85 Construction details

<p>Penetration seal: Combustible pipes sealed with Protecta FR Pipe Wrap, installed into Protecta EX Mortar seals. Minimum separation between penetration seals and seal edges of 30 mm. Minimum seal size as section 4.1 dot point 4.</p>	
<p>Construction details:</p>	
<p>Configuration 1</p>	<p>Configuration 2</p>
<p>Key: 1 Supporting construction a1 Pipe / top edge of seal separation a2 Pipe / side edge of seal separation a3 Pipe / pipe separation</p>	
<p>Note *Partition wall must incorporate a full fill core insulation of Stonewool (35 kg/m³ density).</p>	

Table 86 Double side penetration seal with pipes

Services	Wraps (both sides)	Permitted configuration for seal separation	FRL
PVC-U pipes			
Diameter up to 40 mm, wall thickness 3.0 – 4.3 mm	50 mm × 1.8 mm (1 layer)	1 & 2 between PVC-U/PVC-C, PE/ABS/SAN+PVC and PP pipes in any combination	-/120/60 U/C, C/C
Diameter up to 110 mm, wall thickness 2.7 - 6.6 mm	50 mm × 3.6 mm (2 × 1.8 layer)		-/120/90 U/C, C/C
Diameter up to 125 mm, wall thickness 3.7 – 7.4 mm	50 mm × 5.4 mm (3 × 1.8 layer)		-/120/120 U/C, C/C
Diameter up to 160 mm, wall thickness 3.2 - 9.5 mm	50 mm × 7.2 mm (4 × 1.8 layer)		-/60/60 U/C, C/C
PE pipes			
Diameter up to 40 mm, wall thickness 3.2 – 3.7 mm	50 mm × 1.8 mm (1 layer)	1 & 2 between PVC-U/PVC-C, PE/ABS/SAN+PVC and PP pipes in any combination	-/120/120 U/C, C/C
Diameter up to 110 mm, wall thickness 4.2 – 10 mm	50 mm × 3.6 mm (2 × 1.8 layer)		-/60/60 U/C, C/C
Diameter up to 125 mm, wall thickness 12.0 mm	50 mm × 5.4 mm (3 × 1.8 layer)		-/120/120 U/C, C/C
Diameter up to 160 mm, wall thickness 4.9 - 12.0 mm	50 mm × 7.2 mm (4 × 1.8 layer)		-/120/120 U/C, C/C
Diameter up to 160 mm, wall thickness 12.0 mm			-/90/90 U/C, C/C
PP pipes			
Diameter up to 40 mm, wall thickness 4.0 – 5.5 mm	50 mm × 1.8 mm (1 layer)	1 & 2 between PVC-U/PVC-C, PE/ABS/SAN+PVC and PP pipes in any combination	-/120/120 U/C, C/C
Diameter up to 110 mm, wall thickness 6.6 mm	50 mm × 3.6 mm (2 × 1.8 layer)		-/120/90 U/C, C/C
Diameter up to 125 mm, wall thickness 17.1 mm	50 mm × 5.4 mm (3 × 1.8 layer)		-/120/90 U/C, C/C
Diameter up to 160 mm, wall thickness 4.0 – 21.9 mm	50 mm × 7.2 mm (4 × 1.8 layer)		-/120/120 U/C, C/C
Diameter up to 160 mm, wall thickness 21.9 mm			-/60/60 U/C, C/C

6.7.8 Pipe penetration seal with 50 mm deep Protecta EX Mortar to both faces

Table 87 Construction details

Penetration seal: CS (Continuous Sustained) insulated metallic pipes fitted at any position within the aperture (min. separation 30 mm from seal edges), min. 50 mm Protecta EX Mortar to both sides of the wall without backing*. Protecta FR Pipe wraps are required to be fitted to both faces of the seal.	
Construction details:	
Configuration 1	Configuration 2
Key: 1 Supporting construction a1 Pipe / top edge of seal separation a2 Pipe / side edge of seal separation a3 Pipe / pipe separation	
Note: *Maximum seal size as section 4.1 dot point 4.	

Table 88 Double side penetration seal with pipes

Services	Wrap	Insulation	FRL
Mild or stainless steel pipes			
40 mm diameter/1-14.2 mm wall*	2 off 50 mm × 3.6 mm Protecta FR Pipe Wrap, one fitted flush to each face of seal	13 - 32 mm Elastomeric insulation minimum class B-s3,d0 or PE Foam insulation	-/120/60 C/U
50 mm diameter/1.3-14.2 mm wall*			
60 mm diameter/1.6-14.2 mm wall*			
75 mm diameter/2-14.2 mm wall*			
90 mm diameter/2.4-14.2 mm wall*			
100 mm diameter/2.7-14.2 mm wall*			
115 mm diameter/3.1-14.2 mm wall*			
140 mm diameter/3.8-14.2 mm wall*			
165 mm diameter/ 4.5-14.2 mm wall*			
Note: *Typical pipe diameters shown, see below graph in Figure 51 for intermediate sizes			

Pipe diameter vs Wall thickness

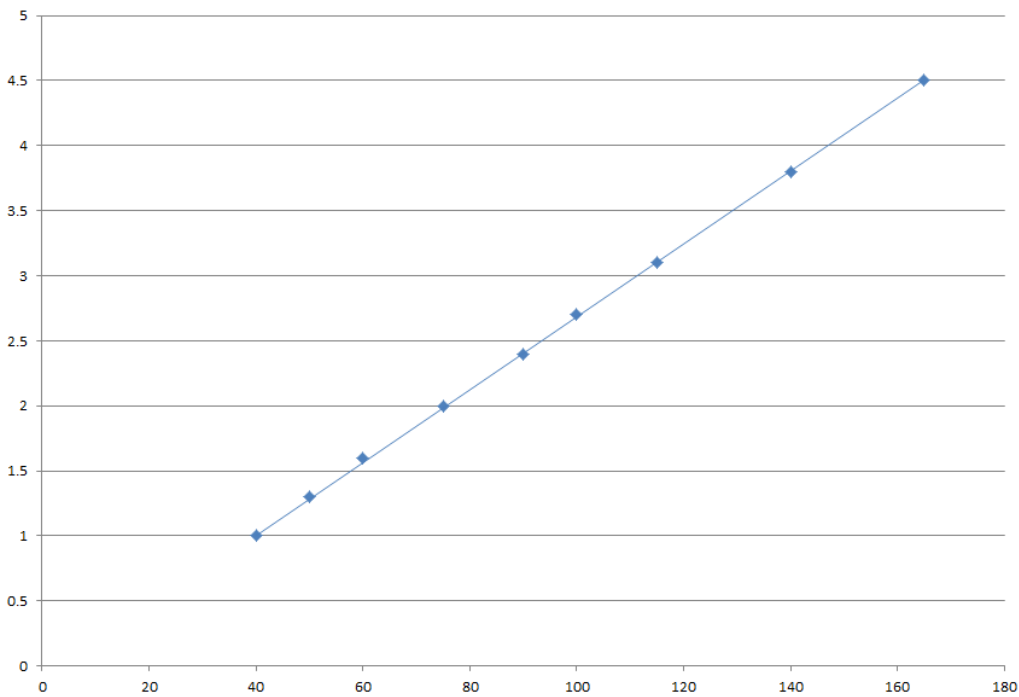

Figure 51 Intermediate pipe wall thicknesses for typical steel pipes

7.0 Assessment 3 – Assessment of specific variations

7.1 Description of variation

It is proposed that the separating elements are varied as follows:

- + Increase in aperture size for fire seals filled with Protecta Ex mortar
- + Test results from floors as applicable to walls.
- + The plasterboard wall partition assessed shall include the option of lining with two layers of minimum 13 mm thick fire grade plasterboard that has otherwise been tested or assessed as a wall to achieve a FRL -/120/120 on each side of steel or timber framed wall.
- + Applying test results obtained to masonry, AAC or concrete walls and bare rigid walls having minimum thickness of 75 mm.
- + Wall thickness is reduced from 150 mm to 100 mm for section 6.3.5 and floor thickness is reduced from 150 mm as tested to 100 mm for assessed systems in sections 6.4.5 and 6.4.7.

It is proposed that the integrity rating achieved for insulated pipes can be applied to uninsulated pipes as shown in sections 6.3.3, 6.3.8, 6.4.2 and 6.4.6.

7.2 Methodology

The method of assessment used is summarised in Table 89.

Table 89 Method of assessment

Assessment method	
Level of complexity	Complex assessment
NCC procedure for determining fire performance	Differs in only a minor degree from a tested prototype S1C2(b) and S1C2(c)
Type of assessment	Qualitative and comparative

7.3 Assessment

7.3.1 Increase in aperture size for fire seals filled with Protecta Ex mortar

It is proposed that the Protecta EX Mortar may be used to seal apertures in the separating element up to 2400 mm wide by 1200 mm high in a wall, and 2400 mm by 1200 mm in a floor. The additional sizes that are permitted in floors are as shown in Table 90.

Table 90 Permitted size in floors

Width (mm)	Length (mm)
1100	2620
1000	2880
≤ 800	∞ (infinite)

The maximum aperture size tested with Protecta Ex Mortar is 2400 mm long by 1200 mm wide – in specimen A of WF 375797. Considering the plan dimensions of the mortar-filled aperture, the aspect ratio is 2:1 which indicates that it can be considered as a one-way slab in which the bending is primarily about the long axis. Provided that the dimensions of the aperture are increased so that the aspect ratio is equal to or

greater than 2:1, the Protecta EX mortar will act as a one-way slab with the same load paths as the tested blank seal. This means that all loads applied onto the aperture will be transferred along the same supporting edges (long edges) as that of the tested system and so the mortar is not expected to detach from the edges and will remain in place. Therefore, the integrity of the seal is not expected to be detrimentally affected by the proposed increase in dimensions.

7.3.2 Applicability of test results from floors to walls

Due to the increased furnace pressure requirement for the floor orientation and the tendency for gravity to cause a cave-in effect to the slab and mortar in this orientation, it is considered that test results obtained from horizontal separating elements can be applied to less onerous vertical wall separating elements of the same thickness as the tested Protecta EX mortar depth, which is minimum 100 mm.

7.3.3 Variation to plasterboard lined wall

It is proposed that the plasterboard wall partition tested in the referenced tests shall include the option of lining with two layers of minimum 13 mm thick fire grade plasterboard that has otherwise been tested or assessed as a wall to achieve an FRL of -/120/120 on each side of steel or timber framed wall. It should be noted that the minimum flexible wall thickness outlined in this report or in the referenced test must be met.

7.3.4 Applicability to masonry, AAC or concrete walls

AS 1530.4:2014 Clause 10.12.2 (c), allows the application of test results obtained in plasterboard-lined partitions to be applied to solid or hollow masonry or normal weight concrete walls of the same or greater thickness. Therefore, it is considered this variation/application is feasible.

7.3.5 Variation to floor thickness

It is proposed that the construction is similar to the system showed in sections 6.3.5, 6.4.5 and 6.4.7 subject to the below requirements.

Wall thickness is reduced from 150 mm to 100 mm for section 6.3.5 and floor thickness is reduced from 150 mm as tested to 100 mm for assessed systems in sections 6.4.5 and 6.4.7.

Upon closer inspection of test specimens consisting of pipes penetrating a 150 mm thick floor slab sealed with 100 mm Protecta EX Mortar, it is identified that the temperature rise measured by the thermocouple placed on the Protecta EX Mortar did not exceed 100°C for the duration of the test, which gives confidence in the sealing and fire protection provided by the Protecta EX Mortar.

It is proposed that the floor thickness is reduced to 100 mm, maintaining the depth of applied Protecta EX Mortar at 100 mm (full depth of floor slab). Since, despite the reduction in floor thickness, the depth of the Protecta EX Mortar is maintained at 100 mm, the temperature measured on the seal is also expected to be maintained at less than 100°C for the time of the test duration.

It is also proposed that, in 100 mm thick floor slabs, the mortar is installed to a depth of 50 mm on 50 mm deep stonewool with minimum density of 150 kg/m³. The above discussion can be applied to this system as long as the total depth of the mortar and stonewool backing is maintained at minimum 100 mm.

However, the nominated FRL shall be governed by the FRL of the flooring system provided that it has been tested or assessed by others to achieve that FRL.

Therefore, it is considered that the proposed construction will not introduce any detrimental effect to the integrity and insulation performance of the systems, and hence can be positively assessed.

7.3.6 Applicability of results to uninsulated pipes

It is proposed that the integrity rating achieved for insulated pipes is applied to uninsulated pipes as shown in sections 6.3.3, 6.3.8, 6.4.2 and 6.4.6.

As per AS 1530.4:2014, a specimen shall be deemed to have failed the integrity criterion in when any of the following occur:

- + Sustained flaming for 10 seconds
- + A gap form that allows the passage of hot gases to the unexposed face and ignite the cotton pad when applied for up to 30 seconds
- + A gap forms that allows the penetration of a 25 mm gap gauge anywhere on the specimen
- + A gap forms that allows a 6 mm × 150 mm gap gauge to penetrate the specimen (anywhere on the specimen).

Upon closer inspection of the tested specimens, it was observed that the above systems were able to maintain integrity performance for the duration of the test with no significant observations on cracks or gaps forming around the penetration on the unexposed side that could have promoted an integrity failure. Moreover, it is acknowledged that the insulation provided on the metallic and composite pipes is for insulation rating purposes only as it was interrupted and did not continue through the penetration.

Therefore, it is established that the insulation around the pipes has no bearing on the fire integrity rating of the system and assuming that the insulation rating is zero, removing the insulation on the pipe systems will not cause any detrimental effect to the integrity rating of the pipe system. This variation can therefore be positively assessed.

7.3.7 Applicability in both walls and floors

It was confirmed that the tested Polyethylene pipes were PE100 which as confirmed by report sponsor and pipe manufacturer is similar to HDPE pipes. Therefore, the FRLs shown for PE pipes in section 6 are applicable to HDPE pipes.

Test results for cables remain valid if the diameter of a single cable is reduced and/or number of cables in a bunch is reduced provided that overall diameter of the bunch of any individual cable is not greater than tested. The test results obtained with standard configuration covers all types of insulated cables with copper or aluminium conductors, fibre optic cables and bundled communication cables, except hollow cables.

Results obtained from tests where the supports pass through the seal are applicable to those situations where the support is not continued but not vice versa

The test results obtained using standard configuration for cable penetration systems are valid for:

- + All type of steel cable trays and ladders
- + Any penetration size equal or smaller than that tested, provided the total amount of cross sections of the cables (core and insulation) does not exceed 60% of the penetration.

Support of services in walls and floors must be maintained as per AS 1530.4:2014 and AS 4072.1:2005 requirements.

8.0 Validity

Jensen Hughes does not endorse the tested or assessed products and systems in any way. The conclusions of this assessment may be used to directly assess fire resistance, but it should be recognised that a single test method will not provide a full assessment of fire resistance under all conditions.

Due to the nature of fire testing and the consequent difficulty in quantifying the uncertainty of measurement, it is not possible to provide a stated degree of accuracy. The inherent variability in test procedures, materials and methods of construction, and installation may lead to variations in performance between elements of similar construction.

This assessment is based on test data, information and experience available at the time of preparation. If contradictory evidence becomes available to the assessing authority, the assessment will be unconditionally withdrawn and the report sponsor will be notified in writing. Similarly, the assessment should be re-evaluated, if the assessed construction is subsequently tested since actual test data is deemed to take precedence.

The sponsor is responsible for formally notifying Jensen Hughes of any additional testing performed on their product/system. This obligation applies regardless of where the test was conducted, the results of the test, or whether it was initially considered part of Jensen Hughes' ongoing assessment. The primary goal of this notification is to allow Jensen Hughes to review the changes and determine whether they require re-evaluation or re-testing to determine whether the changes have affected the product's performance. It is important that the client promptly notify Jensen Hughes if any such changes are implemented.

The procedures for the conduct of tests and the assessment of test results are subject to constant review and improvement. The sponsor is therefore recommended that this report be reviewed on, or before, the stated expiry date.

This assessment represents our opinion about the performance of the proposed systems that is expected to be demonstrated when subjected to test conditions in accordance with AS 1530.4:2014, based on the evidence referred to in this report.

This assessment is provided to Firestop Centre Limited for their own specific purposes. This report may be used as evidence of suitability in accordance with the requirements of the relevant National Construction Code. Building certifiers and other third parties must determine the suitability of the systems described in this report for a specific installation.

Appendix A Drawings and additional information

Table 91 Details of drawings

Figures	Source
All drawings of construction details and graphical representation of intermediate service diameters and wall thicknesses as provided in section 6.0.	Extracted from the European Technical Assessment ETA-21/0071 of 2021/01/01 provided by Polyseam Ltd.

Appendix B Summary of supporting test data

B.1 Test report – WF 416697

Table 92 Information about test report

Item	Information about test report
Report sponsor	Polyseam Ltd, St Andrews Road, Huddersfield, West Yorkshire, HD1, 6SB, UK.
Test laboratory	Warringtonfire, Chiltern House, Stocking Lane, High Wycombe, HP14, 4ND, UK.
Test date	The fire resistance test was done on 14 August 2019.
Test standards	The test was done in accordance with BS EN 1363-1:2012 and BS EN 1366-3:2009.
Variation to test standards	None
General description of tested specimen	The supporting construction comprised of a 100 mm thick reinforced AAC lintel ring beam built on top of a 1.5 m × 1.5 m furnace aperture. The aperture was 1100 mm high × 1100 mm wide × 100 mm deep and filled with Protecta EX Mortar fitted flush with the exposed face of the supporting construction.
Instrumentation	The test report states that the instrumentation was in accordance with BS EN 1363-1:2012 and BS EN 1366-3:2009.

The test specimen achieved the following results – see Table 93.

Table 93 Results summary for this test report

Specimen	Aperture	FRL
Protecta EX Mortar fitted flush with the exposed face of the supporting construction.	1100 mm high × 1100 mm wide × 100 mm deep	-/240/240

B.2 Test report – WF 394948

Table 94 Information about test report

Item	Information about test report
Report sponsor	Polyseam Ltd, St Andrews Road, Huddersfield, West Yorkshire, HD1, 6SB, UK.
Test laboratory	Warringtonfire, Chiltem House, Stocking Lane, High Wycombe, HP14, 4ND, UK.
Test date	The fire resistance test was done on 30 January 2018.
Test standards	The test was done in accordance with BS EN 1363-1:2012 and BS EN 1366-3:2009..
Variation to test standards	None
General description of tested specimen	The supporting construction comprised of a 150 mm thick reinforced AAC lintel ring beam built on top of a 1.5 m × 1.5 m furnace aperture. The services referenced in this assessment report are J1-J3. All pipes and cables measured 1200 mm long with a minimum of 500 mm protruding from the exposed face. J1-J3 were tested capped on both faces.
Instrumentation	The test report states that the instrumentation was in accordance with BS EN 1363-1:2012 and BS EN 1366-3:2009.

The test specimen achieved the following results – see Table 95.

Table 95 Results summary for this test report

Specimen	Aperture	Seal description	Service insulation	FRL
J1 - Geberit Mepla Alupex pipe with an outer diameter of 75 mm and a pipe wall thickness of 4.6 mm	Ø 175 mm	Pipe capping: C/C Protecta EX Mortar 50 mm thick cast around pipe. 50 mm thick Stonewool mineral fibre insulation batt (140 kg/m ³ density) fitted flush with the exposed face.	50 mm thick Isover CLIMPIPE section Alu2 glaswool insulation	-/120/120
J2 - Geberit Mepla Alupex pipe with an outer diameter of 16 mm and a pipe wall thickness of 2.25 mm	Ø 56 mm	Pipe capping: C/C Protecta EX Mortar 50 mm thick cast around pipe. 50 mm thick Stonewool mineral fibre insulation batt (140 kg/m ³ density) fitted flush with the exposed face.	20 mm thick Isover CLIMPIPE section Alu2 glaswool insulation	-/180/180
J3 - Geberit Mepla Alupex pipe with an outer diameter of 75 mm and a pipe wall thickness of 4.6 mm	Ø 125 mm	Pipe capping: C/C Protecta EX Mortar 50 mm thick cast around pipe. 50 mm thick Stonewool mineral fibre insulation batt (140 kg/m ³ density) fitted flush with the exposed face.	25 mm thick Isover CLIMPIPE section Alu2 glaswool insulation	-/180/180

B.3 Test report – 405610

Table 96 Information about test report

Item	Information about test report
Report sponsor	Polyseam Ltd, St Andrews Road, Huddersfield, West Yorkshire, HD1, 6SB, UK.
Test laboratory	Warringtonfire, Chiltem House, Stocking Lane, High Wycombe, HP14, 4ND, UK.
Test date	The fire resistance test was done on 11 October 2018.
Test standards	The test was done in accordance with BS EN 1363-1:2012 and BS EN 1366-3:2009.
Variation to test standards	None
General description of tested specimen	The supporting construction comprised of a 150 mm thick reinforced AAC lintel ring beam built on top of a 1.5 m × 1.5 m furnace aperture. The services referenced in this assessment report are G1-G4. All pipes and cables measured 1200 mm long with a minimum of 500 mm protruding from the exposed face. G1 was tested capped on the exposed face and G2-G4 were tested capped on both faces.
Instrumentation	The test report states that the instrumentation was in accordance with BS EN 1363-1:2012 and BS EN 1366-3:2009.

The test specimen achieved the following results – see Table 97.

Table 97 Results summary for this test report

Specimen	Aperture	Seal description	Service insulation	FRL
G1 - Steel pipe with an outer diameter of 324 mm and a pipe wall thickness of 6.35 mm	Ø 324 mm	Pipe capping: C/U Protecta EX Mortar 50 mm thick cast around pipe. 50 mm thick Stonewool mineral fibre insulation batt (140 kg/m ³ density) fitted flush with the exposed face.	None	-/240/-
G2 - Copper pipe with an outer diameter of 12 mm and a pipe wall thickness of 0.7 mm	Ø 12 mm	Pipe capping: C/C Protecta EX Mortar 50 mm thick cast around pipe. 50 mm thick Stonewool mineral fibre insulation batt (140 kg/m ³ density) fitted flush with the exposed face.	None	-/240/30
G3 - Copper pipe with an outer diameter of 54 mm and a pipe wall thickness of 0.7 mm	Ø 54 mm	Pipe capping: C/C Protecta EX Mortar 50 mm thick cast around pipe. 50 mm thick Stonewool mineral fibre insulation batt (140 kg/m ³ density) fitted flush with the exposed face.	None	-/240/-
G3 – Gerberit Mepla (MLC) pipe with an outer diameter of 75 mm and a pipe wall thickness of 4.6 mm	Ø 75 mm	Pipe capping: C/C Protecta EX Mortar 50 mm thick cast around pipe. 50 mm thick Stonewool mineral fibre insulation batt (140 kg/m ³ density) fitted flush with the exposed face.	None	-/180/30

B.4 Test report – WF 405532 REVISION A

Table 98 Information about test report

Item	Information about test report
Report sponsor	Polyseam Ltd, St Andrews Road, Huddersfield, West Yorkshire, HD1, 6SB, UK.
Test laboratory	Warringtonfire, Chiltem House, Stocking Lane, High Wycombe, HP14, 4ND, UK.
Test date	The fire resistance test was done on 8 October 2018.
Test standards	The test was done in accordance with BS EN 1363-1:2012 and BS EN 1366-3:2009.
Variation to test standards	None
General description of tested specimen	The supporting construction comprised of a 150 mm thick reinforced AAC lintel ring beam built on top of a 1.5 m × 1.5 m furnace aperture. The services referenced in this assessment report are A1-A4, C1, C3 and D1-D3. All pipes and cables measured 1200 mm long with a minimum of 500 mm protruding from the exposed face.
Instrumentation	The test report states that the instrumentation was in accordance with BS EN 1363-1:2012 and BS EN 1366-3:2009.

The test specimen achieved the following results – see Table 99.

Table 99 Results summary for this test report

Specimen	Aperture	Seal description	Service insulation	FRL
A1 – PE pipe with an outer diameter of 50 mm and a pipe wall thickness of 4.6 mm	Ø 68 mm	Pipe capping: C/C Protecta EX Mortar 100 mm thick cast around pipe. Two layers of Protecta FR wrap, fitted flush with the exposed face of the fire seal (size 50 mm wide × 1.8 mm thick each layer. Overall, 3.6 mm thick)	9 mm thick Kaiflex ST	-/240/240
A2 – PP pipe with an outer diameter of 50 mm and a pipe wall thickness of 4.6 mm	Ø 68 mm	Pipe capping: C/C Protecta EX Mortar 100 mm thick cast around pipe. Two layers of Protecta FR wrap, fitted flush with the exposed face of the fire seal (size 50 mm wide × 1.8 mm thick each layer. Overall, 3.6 mm thick)	9 mm thick Kaiflex ST	-/240/180
A3 – PE pipe with an outer diameter of 50 mm and a pipe wall thickness of 3.0 mm	Ø 68 mm	Pipe capping: C/C Protecta EX Mortar 100 mm thick cast around pipe. Two layers of Protecta FR wrap, fitted flush with the exposed face of the fire seal (size 50 mm wide × 1.8 mm thick each layer. Overall, 3.6 mm thick)	9 mm thick Kaiflex ST	-/240/240
A4 – PP pipe with an outer diameter of 50 mm and a pipe wall thickness of 1.8 mm	Ø 68 mm	Pipe capping: C/C Protecta EX Mortar 100 mm thick cast around pipe. Two layers of Protecta FR wrap, fitted flush with the exposed face of the fire seal (size 50 mm wide × 1.8 mm thick each layer. Overall, 3.6 mm thick)	9 mm thick Kaiflex ST	-/240/180
C1 – PE pipe with an outer diameter of 160 mm and a pipe wall thickness of 4.9 mm	Ø 178 mm	Pipe capping: C/C Protecta EX Mortar 120 mm thick cast around pipe. 6 layers of Protecta FR wrap, fitted flush with the exposed face of the fire seal (size 75 mm wide × 1.8 mm thick each layer. Overall, 10.8 mm thick)	9 mm thick Kaiflex ST	-/240/240

Specimen	Aperture	Seal description	Service insulation	FRL
C3 – PE pipe with an outer diameter of 160 mm and a pipe wall thickness of 9.5 mm	Ø 178 mm	Pipe capping: C/C Protecta EX Mortar 120 mm thick cast around pipe. 6 layers of Protecta FR wrap, fitted flush with the exposed face of the fire seal (size 75 mm wide × 1.8 mm thick each layer. Overall, 10.8 mm thick)	9 mm thick Kaiflex ST	-/240/240
D1 – PP pipe with an outer diameter of 160 mm and a pipe wall thickness of 4.9 mm	Ø 178 mm	Pipe capping: C/C Protecta EX Mortar 120 mm thick cast around pipe. 6 layers of Protecta FR wrap, fitted flush with the exposed face of the fire seal (size 75 mm wide × 1.8 mm thick each layer. Overall, 10.8 mm thick)	9 mm thick Kaiflex ST	-/240/240
D2 – Copper pipe with an outer diameter of 12 mm and a pipe wall thickness of 0.7 mm	Ø 12 mm	Pipe capping: C/C Protecta EX Mortar 120 mm thick cast around pipe.	None.	-/240/180
D3 – PP pipe with an outer diameter of 160 mm and a pipe wall thickness of 9.1 mm	Ø 178 mm	Pipe capping: C/C Protecta EX Mortar 120 mm thick cast around pipe. 6 layers of Protecta FR wrap, fitted flush with the exposed face of the fire seal (size 75 mm wide × 1.8 mm thick each layer. Overall, 10.8 mm thick)	9 mm thick Kaiflex ST	-/240/240

B.5 Test report – WF 400805

Table 100 Information about test report

Item	Information about test report
Report sponsor	Polyseam Ltd, St Andrews Road, Huddersfield, West Yorkshire, HD1, 6SB, UK.
Test laboratory	Warringtonfire, Chiltem House, Stocking Lane, High Wycombe, HP14, 4ND, UK.
Test date	The fire resistance test was done on 8 November 2018.
Test standards	The test was done in accordance with BS EN 1363-1:2012 and BS EN 1366-3:2009.
Variation to test standards	None
General description of tested specimen	The supporting construction comprised of a 150 mm thick reinforced AAC lintel ring beam built on top of a 1.5 m × 1.5 m furnace aperture. The services referenced in this assessment report are C1-C3. All pipes and cables measured 1200 mm long with a minimum of 500 mm protruding from the exposed face. Pipes C1 and C3 were tested capped on the unexposed face. Pipe C2 was tested uncapped on both faces.
Instrumentation	The test report states that the instrumentation was in accordance with BS EN 1363-1:2012 and BS EN 1366-3:2009.

The test specimen achieved the following results – see Table 101.

Table 101 Results summary for this test report

Specimen	Aperture	Seal description	Service insulation	FRL
C1 – Blue Power Multiplayer pipe with an outer diameter of 110 mm and a pipe wall thickness of 3.4 mm	Pipe and FR Wrap cast into EX Mortar	Pipe capping: U/C Protecta EX Mortar 100 mm thick cast around pipe. Two layers of Protecta FR wrap, fitted flush with the exposed face of the fire seal (size 50 mm wide × 1.8 mm thick each layer. Overall, 3.6 mm thick)	None	-/120/120
C2 – Blue Power Multiplayer pipe with an outer diameter of 50 mm and a pipe wall thickness of 1.8 mm	Pipe and FR Wrap cast into EX Mortar	Pipe capping U/U Protecta EX Mortar 100 mm thick cast around pipe. Two layers of Protecta FR wrap, fitted flush with the exposed face of the fire seal (size 50 mm wide × 1.8 mm thick each layer. Overall, 3.6 mm thick)	None	-/240/240
C3 – Blue Power Multiplayer pipe with an outer diameter of 160 mm and a pipe wall thickness of 4.9 mm	Pipe and FR Wrap cast into EX Mortar	Pipe capping U/U Protecta EX Mortar 100 mm thick cast around pipe. 6 layers of Protecta FR wrap, fitted flush with the exposed face of the fire seal (size 50 mm wide × 1.8 mm thick each layer. Overall, 10.6 mm thick)	None	-/240/240

B.6 Test report – WF 400806

Table 102 Information about test report

Item	Information about test report
Report sponsor	Polyseam Ltd, St Andrews Road, Huddersfield, West Yorkshire, HD1, 6SB, UK.
Test laboratory	Warringtonfire, Chiltem House, Stocking Lane, High Wycombe, HP14, 4ND, UK.
Test date	The fire resistance test was done on 25 October 2018.
Test standards	The test was done in accordance with BS EN 1363-1:2012 and BS EN 1366-3:2009.
Variation to test standards	None
General description of tested specimen	The supporting construction comprised of a 150 mm thick reinforced AAC lintel ring beam built on top of a 1.5 m × 1.5 m furnace aperture. The services referenced in this assessment report are G1-G4. All pipes and cables measured 1200 mm long with a minimum of 500 mm protruding from the exposed face. Pipes G1-G4 were tested capped on both faces.
Instrumentation	The test report states that the instrumentation was in accordance with BS EN 1363-1:2012 and BS EN 1366-3:2009.

The test specimen achieved the following results – see Table 103.

Table 103 Results summary for this test report

Specimen	Aperture	Seal description	Service insulation	FRL
G1 – PVC pipe with an outer diameter of 200 mm and a pipe wall thickness of 11.9 mm	Pipe and FR Wrap cast into EX Mortar	Pipe capping: C/C Protecta EX Mortar 100 mm thick cast around pipe. 6 layers of Protecta FR wrap, fitted flush with the exposed face of the fire seal (size 75 mm wide × 1.8 mm thick each layer. Overall, 10.8 mm thick)	None	-/240/240
G2 – PE pipe with an outer diameter of 200 mm and a pipe wall thickness of 18.2 mm	Pipe and FR Wrap cast into EX Mortar	Pipe capping: C/C Protecta EX Mortar 100 mm thick cast around pipe. 6 layers of Protecta FR wrap, fitted flush with the exposed face of the fire seal (size 75 mm wide × 1.8 mm thick each layer. Overall, 10.8 mm thick)	None	-/240/240
G3 – PVC pipe with an outer diameter of 200 mm and a pipe wall thickness of 4.9 mm	Pipe and FR Wrap cast into EX Mortar	Pipe capping: C/C Protecta EX Mortar 100 mm thick cast around pipe. 6 layers of Protecta FR wrap, fitted flush with the exposed face of the fire seal (size 75 mm wide × 1.8 mm thick each layer. Overall, 10.8 mm thick)	None	-/240/240
G4 – PE pipe with an outer diameter of 200 mm and a pipe wall thickness of 6.2 mm	Pipe and FR Wrap cast into EX Mortar	Pipe capping: C/C Protecta EX Mortar 100 mm thick cast around pipe. 6 layers of Protecta FR wrap, fitted flush with the exposed face of the fire seal (size 75 mm wide × 1.8 mm thick each layer. Overall, 10.8 mm thick)	None	-/240/240

B.7 Test report – WF 397686 Revision A

Table 104 Information about test report

Item	Information about test report
Report sponsor	Polyseam Ltd, St Andrews Road, Huddersfield, West Yorkshire, HD1, 6SB, UK.
Test laboratory	Warringtonfire, Chiltem House, Stocking Lane, High Wycombe, HP14, 4ND, UK.
Test date	The fire resistance test was done on 28 March 2018.
Test standards	The test was done in accordance with BS EN 1363-1:2012 and BS EN 1366-3:2009.
Variation to test standards	None
General description of tested specimen	The supporting construction comprised of a 150 mm thick reinforced AAC lintel ring beam built on top of a 1.5 m × 1.5 m furnace aperture. The services referenced in this assessment report are E1 and E3. All pipes and cables measured 1200 mm long with a minimum of 500 mm protruding from the exposed face. Pipes E1 and E3 were tested capped on both faces.
Instrumentation	The test report states that the instrumentation was in accordance with BS EN 1363-1:2012 and BS EN 1366-3:2009.

The test specimen achieved the following results – see Table 105.

Table 105 Results summary for this test report

Specimen	Aperture	Seal description	Service insulation	FRL
E1 – PP pipe with an outer diameter of 200 mm and a pipe wall thickness of 18.2 mm	Ø 200 mm	Pipe capping: C/C Protecta EX Mortar 120 mm thick cast around pipe. 6 layers of Protecta FR wrap, fitted flush with the exposed face of the fire seal (size 75 mm wide × 1.8 mm thick each layer. Overall, 10.8 mm thick)	None	-/240/240
E3 – PP pipe with an outer diameter of 200 mm and a pipe wall thickness of 4.9 mm	Ø 200 mm	Pipe capping: C/C Protecta EX Mortar 120 mm thick cast around pipe. 6 layers of Protecta FR wrap, fitted flush with the exposed face of the fire seal (size 75 mm wide × 1.8 mm thick each layer. Overall, 10.8 mm thick)	None	-/240/240

B.8 Test report – WF 392115

Table 106 Information about test report

Item	Information about test report
Report sponsor	Polyseam Ltd, St Andrews Road, Huddersfield, West Yorkshire, HD1, 6SB, UK.
Test laboratory	Warringtonfire, Chiltem House, Stocking Lane, High Wycombe, HP14, 4ND, UK.
Test date	The fire resistance test was done on 16 November 2017.
Test standards	The test was done in accordance with BS EN 1363-1:2012 and BS EN 1366-3:2009.
Variation to test standards	None
General description of tested specimen	The supporting construction comprised of a 150 mm thick reinforced AAC lintel ring beam built on top of a 1.5 m × 1.5 m furnace aperture. The service referenced in this assessment report is C. All pipes and cables measured 1200 mm long with a minimum of 500 mm protruding from the exposed face. Pipe C was tested capped on both faces.
Instrumentation	The test report states that the instrumentation was in accordance with BS EN 1363-1:2012 and BS EN 1366-3:2009.

The test specimen achieved the following results – see Table 107.

Table 107 Results summary for this test report

Specimen	Aperture	Seal description	Service insulation	FRL
C – PVC pipe with an outer diameter of 400 mm and a pipe wall thickness of 15.3 mm	Ø 400 mm	Pipe capping: C/C Protecta EX Mortar 120 mm thick cast around pipe. 16 layers of Protecta FR wrap, fitted flush with the exposed face of the fire seal (size 75 mm wide × 1.8 mm thick each layer)	None	-/60/60

B.9 Test report – WF 19324A

Table 108 Information about test report

Item	Information about test report
Report sponsor	Polyseam Ltd, St Andrews Road, Huddersfield, West Yorkshire, HD1, 6SB, UK.
Test laboratory	WFRGENT NV, Ottergemsesteenweg-Zuid 711, B-9000, Gent, Belgie.
Test date	The fire resistance test was done on 31 October 2018.
Test standards	The test was done in accordance with BS EN 1363-1:2012 and BS EN 1366-3:2009.
Variation to test standards	None
General description of tested specimen	The supporting construction comprised of a 150 mm thick rigid aerated concrete floor with a minimum density of 550 kg/m ³ . The services referenced in this assessment report are B1-4, E1-E2, A11-A14 and AM. The service length is at least 500 mm on both sides of the supporting construction.
Instrumentation	The test report states that the instrumentation was in accordance with BS EN 1363-1:2012 and BS EN 1366-3:2009.

The test specimen achieved the following results – see Table 109.

Table 109 Results summary for this test report

Specimen	Aperture	Seal description	Service insulation	FRL
AI1 – PE pipe with an outer diameter of 160 mm and a pipe wall thickness of 4.9 mm	700 mm × 900 mm	Pipe capping: C/C Protecta EX Mortar 120 mm thick cast around pipe. 10 layers of Protecta FR wrap, fitted flush with the exposed face of the fire seal (size 75 mm wide × 1.8 mm thick each layer, overall thickness 18 mm)	50 mm thick continuous sustained (CS) elastomeric insulation for the full length of the pipe	-/120/120
AI2 – PE pipe with an outer diameter of 160 mm and a pipe wall thickness of 9.5 mm				
AI3 – PP pipe with an outer diameter of 160 mm and a pipe wall thickness of 4.9 mm				
AI4 – PP pipe with an outer diameter of 160 mm and a pipe wall thickness of 9.1 mm				
AM – Agru pipe with an outer diameter of 400 mm and a pipe wall thickness of 22.7 mm	600 mm × 600 mm	Pipe capping: C/C Protecta EX Mortar 150 mm thick cast around pipe. 16 layers of Protecta FR wrap, fitted flush with the exposed face of the fire seal (size 75 mm wide × 1.8 mm thick each layer, overall thickness 28.8 mm)	None	-/60/60
B1 – Steel pipe with an outer diameter of 76 mm and a pipe wall thickness of 1.5 mm	600 mm × 600 mm	Pipe capping: C/U Protecta EX Mortar 150 mm thick cast around pipe. 2 layers of Protecta FR wrap, fitted flush with the exposed face of the fire seal (size 50 mm wide × 1.8 mm thick each layer, overall thickness 3.6 mm)	30 mm thick PE foam insulation for continuous sustained for the full length of the pipe	-/180/90

Specimen	Aperture	Seal description	Service insulation	FRL
B2 – Steel pipe with an outer diameter of 76 mm and a pipe wall thickness of 1.5 mm		Pipe capping: C/U Protecta EX Mortar 150 mm thick cast around pipe. 1 layer of Protecta FR wrap, fitted flush with the exposed face of the fire seal (size 50 mm wide × 1.8 mm thick each layer, overall thickness 1.8 mm)	9 mm thick PE foam insulation for continuous sustained for the full length of the pipe	-/180/60
B3 – Steel pipe with an outer diameter of 63.5 mm and a pipe wall thickness of 1.6 mm		Pipe capping: C/U Protecta EX Mortar 150 mm thick cast around pipe.		-/180/90
B4 – Steel pipe with an outer diameter of 12 mm and a pipe wall thickness of 1.0 mm		Pipe capping: C/U Protecta EX Mortar 150 mm thick cast around pipe. 1 layers of Protecta FR wrap, fitted flush with the exposed face of the fire seal (size 50 mm wide × 1.8 mm thick each layer, overall thickness 1.8 mm)	6 mm thick PE foam insulation for continuous sustained for the full length of the pipe	-/180/180
E1 – PP-MD Uponor Decibel pipe with an outer diameter of 110 mm and a pipe wall thickness of 3.8 mm	300 mm × 250 mm	Pipe capping: U/C Protecta EX Mortar 100 mm thick cast around pipe. 2 layers of Protecta FR wrap, fitted flush with the exposed face of the fire seal (size 50 mm wide × 1.8 mm thick each layer, overall thickness 3.6 mm)	None	-/120/120
E2 – PP-MD Uponor Decibel pipe with an outer diameter of 50 mm and a pipe wall thickness of 1.8 mm		Pipe capping: U/U Protecta EX Mortar 100 mm thick cast around pipe. 2 layers of Protecta FR wrap, fitted flush with the exposed face of the fire seal (size 50 mm wide × 1.8 mm thick each layer, overall thickness 3.6 mm)		

B.10 Test report – WF 375797

Table 110 Information about test report

Item	Information about test report
Report sponsor	Polyseam Ltd, St Andrews Road, Huddersfield, West Yorkshire, HD1, 6SB, UK.
Test laboratory	Exova Warringtonfire, Holmesfield Road, Warrington, WA1, 2DS, UK
Test date	The fire resistance test was done on 9 March 2017.
Test standards	The test was done in accordance with BS EN 1363-1:2012 and BS EN 1366-3:2009.
Variation to test standards	None
General description of tested specimen	The supporting construction comprised of a 150 mm thick rigid aerated concrete floor with a minimum density of 550 kg/m ³ . The supporting construction had overall dimensions of 4000 mm length by 3000 mm width. The service referenced in this assessment report is A.
Instrumentation	The test report states that the instrumentation was in accordance with BS EN 1363-1:2012 and BS EN 1366-3:2009.

The test specimen achieved the following results – see Table 111.

Table 111 Results summary for this test report

Specimen	Seal type	FRL
A	2400 mm long by 1200 mm wide aperture which was sealed with 100 mm thick Polyseam “Protecta® Ex Mortar”. The Mortar was fit within the aperture flush to the exposed face of the supporting construction. The aperture was shuttered out with timber boards and braces with the mortar poured in.	-/240/240

B.11 Test report – WF 375799A

Table 112 Information about test report

Item	Information about test report
Report sponsor	Polyseam Ltd, St Andrews Road, Huddersfield, West Yorkshire, HD1, 6SB, UK.
Test laboratory	Warringtonfire, Chiltem House, Stocking Lane, High Wycombe, HP14, 4ND, UK.
Test date	The fire resistance test was done on 15 January 2016.
Test standards	The test was done in accordance with BS EN 1363-1:2012 and BS EN 1366-3:2009.
Variation to test standards	None
General description of tested specimen	The supporting construction comprised a reinforced AAC lintel floor slab built on top of a 1.5 m × 1.5 m furnace aperture. The floor slab included 10 apertures. The services referenced in this assessment report are B, D, D1-D4, E1-E3. All pipes and cables measured nominally 1200mm long with a minimum of 500 mm protruding from the exposed face. All pipes were tested uncapped on both faces.
Instrumentation	The test report states that the instrumentation was in accordance with BS EN 1363-1:2012 and BS EN 1366-3:2009.

The test specimen achieved the following results – see Table 113.

Table 113 Results summary for this test report

Specimen	Aperture	Seal type	FRL
B – Blank seal	The aperture is 500 mm × 300 mm × 150 mm deep.	50 mm thick Protecta Ex Mortar. Backing material is 50 mm thick Stonewool rock fibre batt (140 kg/m ³ density) fitted flush with the exposed side.	-/240/90
D – Blank seal	The aperture is 200 mm × 200 mm × 150 mm deep.	100 mm thick Protecta Ex Mortar flush with the exposed face.	-/180/120
D1 – PVC pipe with an outer diameter of 40 mm and a pipe wall thickness of 3.7 mm	Ø 40 mm – pipe and intumescent cast into the fire seal	Pipe capping: U/U 100 mm thick Protecta Ex Mortar flush with the exposed face. Protecta FR Wrap 50 mm wide × 1.8 mm thick, fitted flush with the exposed face of the fire seal.	-/180/180
D2 – PE pipe with an outer diameter of 40 mm and a pipe wall thickness of 2.4 mm	Ø 40 mm – pipe and intumescent cast into the fire seal	Pipe capping: U/U 100 mm thick Protecta Ex Mortar flush with the exposed face. Protecta FR Wrap 50 mm wide × 1.8 mm thick, fitted flush with the exposed face of the fire seal.	-/240/240
D3 – PVC pipe with an outer diameter of 40 mm and a pipe wall thickness of 1.8 mm	Ø 40 mm – pipe and intumescent cast into the fire seal	Pipe capping: U/U 100 mm thick Protecta Ex Mortar flush with the exposed face. Protecta FR Wrap 50 mm wide × 1.8 mm thick, fitted flush with the exposed face of the fire seal.	-/180/120
D4 – PE pipe with an outer diameter of 40 mm and a pipe wall thickness of 3.7 mm	Ø 40 mm – pipe and intumescent cast into the fire seal	Pipe capping: U/U 100 mm thick Protecta Ex Mortar flush with the exposed face. Protecta FR Wrap 50 mm wide × 1.8 mm thick, fitted flush with the exposed face of the fire seal.	-/240/240

Specimen	Aperture	Seal type	FRL
E1 – PVC pipe with an outer diameter of 160 mm and a pipe wall thickness of 4.0 mm	Ø 160 mm – pipe and intumescent cast into the fire seal	Pipe capping: U/U 100 mm thick Protecta Ex Mortar flush with the exposed face. Protecta FR Wrap 50 mm wide × 10.8 mm thick, fitted flush with the exposed face of the fire seal.	-/30/-
E2 – PP pipe with an outer diameter of 160 mm and a pipe wall thickness of 14.6 mm	Ø 160 mm – pipe and intumescent cast into the fire seal	Pipe capping: U/U 100 mm thick Protecta Ex Mortar flush with the exposed face. Protecta FR Wrap 50 mm wide × 10.8 mm thick, fitted flush with the exposed face of the fire seal.	No FRL can be provided.
E3 – PP pipe with an outer diameter of 160 mm and a pipe wall thickness of 4.9 mm	Ø 160 mm – pipe and intumescent cast into the fire seal	Pipe capping: U/U 100 mm thick Protecta Ex Mortar flush with the exposed face. Protecta FR Wrap 50 mm wide × 10.8 mm thick, fitted flush with the exposed face of the fire seal.	No FRL can be provided.

B.12 Test report – WF 375799B

Table 114 Information about test report

Item	Information about test report
Report sponsor	Polyseam Ltd, St Andrews Road, Huddersfield, West Yorkshire, HD1, 6SB, UK.
Test laboratory	Warringtonfire, Chiltem House, Stocking Lane, High Wycombe, HP14, 4ND, UK.
Test date	The fire resistance test was done on 23 March 2017.
Test standards	The test was done in accordance with BS EN 1363-1:2012 and BS EN 1366-3:2009.
Variation to test standards	None
General description of tested specimen	The supporting construction comprised a reinforced AAC lintel floor slab built on top of a 1.5 m × 1.5 m furnace aperture. The floor slab included 10 apertures. The services referenced in this assessment report are B, D, D1-D4, E, E1-E3. All pipes and cables measured nominally 1200mm long with a minimum of 500 mm protruding from the exposed face.
Instrumentation	The test report states that the instrumentation was in accordance with BS EN 1363-1:2012 and BS EN 1366-3:2009.

The test specimen achieved the following results – see Table 115.

Table 115 Results summary for this test report

Specimen	Aperture	Seal type	FRL
B – Blank seal	The aperture is 500 mm × 300 mm × 150 mm deep.	50 mm thick Protecta Ex Mortar. Backing material is 50 mm thick Stonewool rock fibre batt (140 kg/m ³ density) fitted flush with the exposed side.	-/180/120
D – Blank seal	The aperture is 500 mm × 500 mm × 150 mm deep.	100 mm thick Protecta Ex Mortar flush with the exposed face.	-/180/60
D1 – PE pipe with an outer diameter of 110 mm and a pipe wall thickness of 3.4 mm	Ø 110 mm – pipe and intumescent cast into the fire seal	Pipe capping: U/C 100 mm thick Protecta Ex Mortar flush with the exposed face. 2 layers of Protecta FR Wrap 50 mm wide × 1.8 mm thick, fitted flush with the exposed face of the fire seal.	-/120/120
D2 – PVC pipe with an outer diameter of 125 mm and a pipe wall thickness of 7.4 mm	Ø 125 mm – pipe and intumescent cast into the fire seal	Pipe capping: U/C 100 mm thick Protecta Ex Mortar flush with the exposed face. 4 layers of Protecta FR Wrap 50 mm wide × 1.8 mm thick, fitted flush with the exposed face of the fire seal.	-/120/120
D3 – PVC pipe with an outer diameter of 160 mm and a pipe wall thickness of 9.5 mm	Ø 160 mm – pipe and intumescent cast into the fire seal	Pipe capping: U/C 100 mm thick Protecta Ex Mortar flush with the exposed face. 6 layers of Protecta FR Wrap 50 mm wide × 1.8 mm thick, fitted flush with the exposed face of the fire seal.	-/60/60
D4 – PE pipe with an outer diameter of 160 mm and a pipe wall thickness of 4.9 mm	Ø 160 mm – pipe and intumescent cast into the fire seal	Pipe capping: U/C 100 mm thick Protecta Ex Mortar flush with the exposed face. 6 layers of Protecta FR Wrap 50 mm wide × 1.8 mm thick, fitted flush with the exposed face of the fire seal.	-/120/120

Specimen	Aperture	Seal type	FRL
E – Blank seal	The aperture is 200 mm × 200 mm × 150 mm deep.	100 mm thick Protecta Ex Mortar flush with the exposed face.	-/120/90
E1 – PVC pipe with an outer diameter of 40 mm and a pipe wall thickness of 1.9 mm	Ø 40 mm – pipe and intumescent cast into the fire seal	Pipe capping: U/U 100 mm thick Protecta Ex Mortar flush with the exposed face. Protecta FR Wrap 50 mm wide × 1.8 mm thick, fitted flush with the exposed face of the fire seal.	-/120/120
E2 – PE pipe with an outer diameter of 40 mm and a pipe wall thickness of 2.4 mm	Ø 40 mm – pipe and intumescent cast into the fire seal	Pipe capping: U/U 100 mm thick Protecta Ex Mortar flush with the exposed face. Protecta FR Wrap 50 mm wide × 1.8 mm thick, fitted flush with the exposed face of the fire seal.	-/180/90
E3 – PP pipe with an outer diameter of 40 mm and a pipe wall thickness of 5.5 mm	Ø 40 mm – pipe and intumescent cast into the fire seal	Pipe capping: U/U 100 mm thick Protecta Ex Mortar flush with the exposed face. Protecta FR Wrap 50 mm wide × 1.8 mm thick, fitted flush with the exposed face of the fire seal.	-/120/120

B.13 Test report – WF 379319

Table 116 Information about test report

Item	Information about test report
Report sponsor	Polyseam Ltd, St Andrews Road, Huddersfield, West Yorkshire, HD1, 6SB, UK.
Test laboratory	Warringtonfire, Chiltem House, Stocking Lane, High Wycombe, HP14, 4ND, UK.
Test date	The fire resistance test was done on 2 February 2017.
Test standards	The test was done in accordance with BS EN 1363-1:2012 and BS EN 1366-3:2009.
Variation to test standards	None
General description of tested specimen	The supporting construction comprised a reinforced AAC lintel floor slab built on top of a 1.5 m × 1.5 m furnace aperture. The floor slab included 10 apertures. The services referenced in this assessment report are A, A1-A3, B1, B4, C1-C2, C4, D, D1-D3. All pipes and cables measured nominally 1200 mm long with a minimum of 500 mm protruding from the exposed face.
Instrumentation	The test report states that the instrumentation was in accordance with BS EN 1363-1:2012 and BS EN 1366-3:2009.

The test specimen achieved the following results – see Table 117.

Table 117 Results summary for this test report

Specimen	Aperture	Seal type	FRL
A – Blank seal	The aperture is 450 mm × 450 mm × 150 mm deep.	100 mm thick Protecta Ex Mortar flush with the exposed face.	-/30/-
A1 – PP pipe with an outer diameter of 160 mm and a pipe wall thickness of 14.6 mm	Ø 160 mm – pipe and intumescent cast into the fire seal	Pipe capping: U/C 100 mm thick Protecta Ex Mortar flush with the exposed face. 6 layers of Protecta FR Wrap 50 mm wide × 1.8 mm thick, fitted flush with the exposed face of the fire seal.	-/240/240
A2 – PVC pipe with an outer diameter of 110 mm and a pipe wall thickness of 2.7 mm	Ø 110 mm – pipe and intumescent cast into the fire seal	Pipe capping: U/U 100 mm thick Protecta Ex Mortar flush with the exposed face. 2 layers of Protecta FR Wrap 50 mm wide × 1.8 mm thick, fitted flush with the exposed face of the fire seal.	-/30/-
A3 – PE pipe with an outer diameter of 125 mm and a pipe wall thickness of 3.9 mm	Ø 125 mm – pipe and intumescent cast into the fire seal	Pipe capping: U/U 100 mm thick Protecta Ex Mortar flush with the exposed face. 4 layers of Protecta FR Wrap 50 mm wide × 1.8 mm thick, fitted flush with the exposed face of the fire seal.	-/240/-
B1 – PE pipe with an outer diameter of 125 mm and a pipe wall thickness of 11.4 mm	Ø 125 mm – pipe and intumescent cast into the fire seal	Pipe capping: U/U 100 mm thick Protecta Ex Mortar flush with the exposed face. 4 layers of Protecta FR Wrap 50 mm wide × 1.8 mm thick, fitted flush with the exposed face of the fire seal.	-/240/240

Specimen	Aperture	Seal type	FRL
B4 – PVC pipe with an outer diameter of 110 mm and a pipe wall thickness of 6.3 mm	Ø 110 mm – pipe and intumescent cast into the fire seal	Pipe capping: U/U 100 mm thick Protecta Ex Mortar flush with the exposed face. 2 layers of Protecta FR Wrap 50 mm wide × 1.8 mm thick, fitted flush with the exposed face of the fire seal.	-/120/30
C1 – PVC pipe with an outer diameter of 125 mm and a pipe wall thickness of 7.4 mm	Ø 125 mm – pipe and intumescent cast into the fire seal	Pipe capping: U/U 100 mm thick Protecta Ex Mortar flush with the exposed face. 4 layers of Protecta FR Wrap 50 mm wide × 1.8 mm thick, fitted flush with the exposed face of the fire seal.	-/30/30
C2 – PP pipe with an outer diameter of 125 mm and a pipe wall thickness of 11.4 mm	Ø 125 mm – pipe and intumescent cast into the fire seal	Pipe capping: U/U 100 mm thick Protecta Ex Mortar flush with the exposed face. 4 layers of Protecta FR Wrap 50 mm wide × 1.8 mm thick, fitted flush with the exposed face of the fire seal.	-/240/240
C4 – PE pipe with an outer diameter of 110 mm and a pipe wall thickness of 3.4 mm	Ø 110 mm – pipe and intumescent cast into the fire seal	Pipe capping: U/U 100 mm thick Protecta Ex Mortar flush with the exposed face. 2 layers of Protecta FR Wrap 50 mm wide × 1.8 mm thick, fitted flush with the exposed face of the fire seal.	-/240/-
D – Blank seal	The aperture is 450 mm × 450 mm × 150 mm deep	100 mm thick Protecta Ex Mortar flush with the exposed face.	-/60/60
D1 – PVC pipe with an outer diameter of 125 mm and a pipe wall thickness of 4.8 mm	Ø 125 mm – pipe and intumescent cast into the fire seal	Pipe capping: U/U 100 mm thick Protecta Ex Mortar flush with the exposed face. 4 layers of Protecta FR Wrap 50 mm wide × 1.8 mm thick, fitted flush with the exposed face of the fire seal.	-/60/60
D2 – PP pipe with an outer diameter of 160 mm and a pipe wall thickness of 4.9 mm	Ø 160 mm – pipe and intumescent cast into the fire seal	Pipe capping: U/C 100 mm thick Protecta Ex Mortar flush with the exposed face. 6 layers of Protecta FR Wrap 50 mm wide × 1.8 mm thick, fitted flush with the exposed face of the fire seal.	-/240/240
D3 – PE pipe with an outer diameter of 110 mm and a pipe wall thickness of 10.0 mm	Ø 110 mm – pipe and intumescent cast into the fire seal	Pipe capping: U/U 100 mm thick Protecta E Mortar flush with the exposed face. 2 layers of Protecta FR Wrap 50 mm wide × 1.8 mm thick, fitted flush with the exposed face of the fire seal.	-/240/240

B.14 Test report – WF 380963

Table 118 Information about test report

Item	Information about test report
Report sponsor	Polyseam Ltd, St Andrews Road, Huddersfield, West Yorkshire, HD1, 6SB, UK.
Test laboratory	Warringtonfire, Chiltem House, Stocking Lane, High Wycombe, HP14, 4ND, UK.
Test date	The fire resistance test was done on 6 March 2017.
Test standards	The test was done in accordance with BS EN 1363-1:2012 and BS EN 1366-3:2009.
Variation to test standards	None
General description of tested specimen	The supporting construction comprised a reinforced AAC lintel floor slab built on top of a 1.5 m × 1.5 m furnace aperture. The floor slab included 10 apertures. The services referenced in this assessment report are J, J1-J9. All pipes and cables measured nominally 1200 mm long with a minimum of 500 mm protruding from the exposed face.
Instrumentation	The test report states that the instrumentation was in accordance with BS EN 1363-1:2012 and BS EN 1366-3:2009.

The test specimen achieved the following results – see Table 119.

Table 119 Results summary for this test report

Specimen	Aperture	Seal type	FRL
J – Blank seal	The aperture is 750 mm × 400 mm × 150 mm deep.	100 mm thick Protecta Ex Mortar flush with the exposed face.	-/60/60
J1 – PE pipe with an outer diameter of 40 mm and a pipe wall thickness of 4.4 mm	Ø 40 mm – pipe and intumescent cast into the fire seal	Pipe capping: U/C 100 mm thick Protecta Ex Mortar flush with the exposed face.	-/180/120
J2 – PP pipe with an outer diameter of 40 mm and a pipe wall thickness of 1.8 mm	Ø 40 mm – pipe and intumescent cast into the fire seal	Pipe capping: U/C 100 mm thick Protecta Ex Mortar flush with the exposed face.	-/120/120
J3 – PHP pipe with an outer diameter of 20 mm and a pipe wall thickness of 2.2 mm	Ø 20 mm – pipe and intumescent cast into the fire seal	Pipe capping: U/C 100 mm thick Protecta Ex Mortar flush with the exposed face.	-/180/180
J4 – PP pipe with an outer diameter of 40 mm and a pipe wall thickness of 4.4 mm	Ø 40 mm – pipe and intumescent cast into the fire seal	Pipe capping: U/C 100 mm thick Protecta Ex Mortar flush with the exposed face.	-/180/120
J5 – PE pipe with an outer diameter of 20 mm and a pipe wall thickness of 2.0 mm	Ø 20 mm – pipe and intumescent cast into the fire seal	Pipe capping: U/C 100 mm thick Protecta Ex Mortar flush with the exposed face.	-/120/120
J6 – PE pipe with an outer diameter of 40 mm and a pipe wall thickness of 3.0 mm	Ø 40 mm – pipe and intumescent cast into the fire seal	Pipe capping: U/C 100 mm thick Protecta Ex Mortar flush with the exposed face.	-/120/120

Specimen	Aperture	Seal type	FRL
Cable transit J7 – Ø 90 mm Type F cable bundle through PP pipe with an outer diameter of 110 mm and a pipe wall thickness of 3.4 mm	Ø 110 mm – pipe and intumescent cast into the fire seal	Pipe capping: U/C 100 mm thick Protecta Ex Mortar flush with the exposed face. 2 layers of Protecta FR Wrap 50 mm wide × 1.8 mm thick, fitted flush with the exposed face of the fire seal.	-/60/60
Cable transit J8 – Ø 90 mm Type F cable bundle through PE pipe with an outer diameter of 110 mm and a pipe wall thickness of 3.4 mm	Ø 110 mm – pipe and intumescent cast into the fire seal	Pipe capping: U/C 100 mm thick Protecta Ex Mortar flush with the exposed face. 2 layers of Protecta FR Wrap 50 mm wide × 1.8 mm thick, fitted flush with the exposed face of the fire seal.	-/120/60
Cable transit J9 – Ø 90 mm Type F cable bundle through PVC pipe with an outer diameter of 110 mm and a pipe wall thickness of 2.7 mm	Ø 110 mm – pipe and intumescent cast into the fire seal	Pipe capping: U/C 100 mm thick Protecta Ex Mortar flush with the exposed face. 2 layers of Protecta FR Wrap 50 mm wide × 1.8 mm thick, fitted flush with the exposed face of the fire seal.	-/120/120

B.15 Test report – WF 382337

Table 120 Information about test report

Item	Information about test report
Report sponsor	Polyseam Ltd, St Andrews Road, Huddersfield, West Yorkshire, HD1, 6SB, UK.
Test laboratory	Warringtonfire, Chiltem House, Stocking Lane, High Wycombe, HP14, 4ND, UK.
Test date	The fire resistance test was done on 19 April 2017.
Test standards	The test was done in accordance with BS EN 1363-1:2012 and BS EN 1366-3:2009.
Variation to test standards	None
General description of tested specimen	The supporting construction comprised a reinforced AAC lintel floor slab built on top of a 1.5 m × 1.5 m furnace aperture. The floor slab included 10 apertures. All pipes and cables measured nominally 1200 mm long with a minimum of 500 mm protruding from the exposed face.
Instrumentation	The test report states that the instrumentation was in accordance with BS EN 1363-1:2012 and BS EN 1366-3:2009.

The test specimen achieved the following results – see Table 121.

Table 121 Results summary for this test report

Specimen	Aperture	Seal type	FRL
1 – Blank seal	The aperture is 450 mm × 450 mm × 150 mm deep.	100 mm thick Protecta Ex Mortar flush with the exposed face.	-/240/240
A1 – PE pipe with an outer diameter of 160 mm and a pipe wall thickness of 14.6 mm	Ø 160 mm – pipe and intumescent cast into the fire seal	Pipe capping: U/C 100 mm thick Protecta Ex Mortar flush with the exposed face. 6 layers of Protecta FR Wrap 50 mm wide × 1.8 mm thick, fitted flush with the exposed face of the fire seal.	-/240/240
A2 – PP pipe with an outer diameter of 110 mm and a pipe wall thickness of 2.7 mm	Ø 110 mm – pipe and intumescent cast into the fire seal	Pipe capping: U/C 100 mm thick Protecta Ex Mortar flush with the exposed face. 2 layers of Protecta FR Wrap 50 mm wide × 1.8 mm thick, fitted flush with the exposed face of the fire seal.	-/240/240
A3 – PP pipe with an outer diameter of 110 mm and a pipe wall thickness of 2.7 mm	Ø 110 mm – pipe and intumescent cast into the fire seal	Pipe capping: U/C 100 mm thick Protecta Ex Mortar flush with the exposed face. 2 layers of Protecta FR Wrap 50 mm wide × 1.8 mm thick, fitted flush with the exposed face of the fire seal.	-/240/240
2 – Blank seal	The aperture is 450 mm × 450 mm × 150 mm deep.	100 mm thick Protecta Ex Mortar flush with the exposed face.	-/240/240
B1 – PP pipe with an outer diameter of 40 mm and a pipe wall thickness of 1.8 mm	Ø 40 mm – pipe and intumescent cast into the fire seal	Pipe capping: U/U 100 mm thick Protecta Ex Mortar flush with the exposed face. 1 layer of Protecta FR Wrap 50 mm wide × 1.8 mm thick, fitted flush with the exposed face of the fire seal.	-/240/240
B2 – PP pipe with an outer diameter of 125 mm and a pipe wall thickness of 3.9 mm	Ø 125 mm – pipe and intumescent cast into the fire seal	Pipe capping: U/C 100 mm thick Protecta Ex Mortar flush with the exposed face. 4 layers of Protecta FR Wrap 50 mm wide × 1.8 mm thick, fitted flush with the exposed face of the fire seal.	-/240/240

Specimen	Aperture	Seal type	FRL
B3 – PP pipe with an outer diameter of 110 mm and a pipe wall thickness of 6.3 mm	Ø 110 mm – pipe and intumescent cast into the fire seal	Pipe capping: U/C 100 mm thick Protecta Ex Mortar flush with the exposed face. 2 layers of Protecta FR Wrap 50 mm wide × 1.8 mm thick, fitted flush with the exposed face of the fire seal.	-/240/240
B4 – PP pipe with an outer diameter of 125 mm and a pipe wall thickness of 11.4 mm	Ø 125 mm – pipe and intumescent cast into the fire seal	Pipe capping: U/C 100 mm thick Protecta Ex Mortar flush with the exposed face. 4 layers of Protecta FR Wrap 50 mm wide × 1.8 mm thick, fitted flush with the exposed face of the fire seal.	-/240/240
3 – Blank seal	The aperture is 450 mm × 450 mm × 150 mm deep.	50 mm thick Protecta Ex Mortar cast around the pipes over 50 mm thick rock mineral fibre (density is 140 kg/m ³) flush to the exposed face.	-/240/30
C1 – Diamond PE-Xb/AL/PE-Xb pipe with an outer diameter of 16 mm and a pipe wall thickness of 2.0 mm	Ø 16 mm – pipe and intumescent cast into the fire seal	Pipe capping: C/C 50 mm thick Protecta Ex Mortar cast around the pipes over 50 mm thick rock mineral fibre (density is 140 kg/m ³) flush to the exposed face.	-/240/240
C2 – Steel pipe with an outer diameter of 16 mm and a pipe wall thickness of 2.0 mm	Ø 16 mm – pipe and intumescent cast into the fire seal	Pipe capping: C/U 50 mm thick Protecta Ex Mortar cast around the pipes over 50 mm thick rock mineral fibre (density is 140 kg/m ³) flush to the exposed face.	-/240/240
C3 – Rodana PE-Xb/AL/PE-Xb pipe with an outer diameter of 20 mm and a pipe wall thickness of 2.0 mm	Ø 20 mm – pipe and intumescent cast into the fire seal	Pipe capping: C/C 50 mm thick Protecta Ex Mortar cast around the pipes over 50 mm thick rock mineral fibre (density is 140 kg/m ³) flush to the exposed face.	-/240/240
D1 – Copper pipe with an outer diameter of 6 mm and a pipe wall thickness of 0.7 mm	Ø 6 mm – pipe and intumescent cast into the fire seal	Pipe capping: C/C 50 mm thick Protecta Ex Mortar cast around the pipes over 50 mm thick rock mineral fibre (density is 140 kg/m ³) flush to the exposed face.	-/240/120
D2 – Copper pipe with an outer diameter of 15 mm and a pipe wall thickness of 0.9 mm	Ø 15 mm – pipe and intumescent cast into the fire seal	Pipe capping: C/C 50 mm thick Protecta Ex Mortar cast around the pipes over 50 mm thick rock mineral fibre (density is 140 kg/m ³) flush to the exposed face.	-/240/30
D3 – Steel pipe with an outer diameter of 4 mm and a pipe wall thickness of 1.0 mm	Ø 4 mm – pipe and intumescent cast into the fire seal	Pipe capping: C/U 50 mm thick Protecta Ex Mortar cast around the pipes over 50 mm thick rock mineral fibre (density is 140 kg/m ³) flush to the exposed face.	-/240/240
E1 – Copper pipe with an outer diameter of 12 mm and a pipe wall thickness of 0.7 mm	Ø 12 mm – pipe and intumescent cast into the fire seal	Pipe capping: C/C 50 mm thick Protecta Ex Mortar cast around the pipes over 50 mm thick rock mineral fibre (density is 140 kg/m ³) flush to the exposed face. 20 mm thick foil faced 80 kg/m ³ stonewool CS	-/240/240

Specimen	Aperture	Seal type	FRL
E2 – Copper pipe with an outer diameter of 54 mm and a pipe wall thickness of 1.2 mm	Ø 54 mm – pipe and intumescent cast into the fire seal	Pipe capping: C/C 50 mm thick Protecta Ex Mortar cast around the pipes over 50 mm thick rock mineral fibre (density is 140 kg/m ³) flush to the exposed face. 20 mm thick foil faced 80 kg/m ³ stonewool CS	-/240/120
E3 – Copper pipe with an outer diameter of 54 mm and a pipe wall thickness of 1.2 mm	Ø 54 mm – pipe and intumescent cast into the fire seal	Pipe capping: C/C 50 mm thick Protecta Ex Mortar cast around the pipes over 50 mm thick rock mineral fibre (density is 140 kg/m ³) flush to the exposed face. 80 mm thick foil faced 80 kg/m ³ stonewool CS	-/240/180
4 – Blank seal	The aperture is 450 mm × 450 mm × 150 mm deep.	100 mm thick Protecta Ex Mortar flush with the exposed face.	No FRL can be provided.
F1 – PVC pipe with an outer diameter of 90 mm and a pipe wall thickness of 2.8 mm	Ø 90 mm – pipe and intumescent cast into the fire seal	Pipe capping: U/U 100 mm thick Protecta Ex Mortar flush with the exposed face. 2 layers of Protecta FR Wrap 50 mm wide × 1.8 mm thick, fitted flush with the exposed face of the fire seal.	-/120/-
F2 – PP pipe with an outer diameter of 90 mm and a pipe wall thickness of 2.8 mm	Ø 90 mm – pipe and intumescent cast into the fire seal	Pipe capping: U/U 100 mm thick Protecta Ex Mortar flush with the exposed face. 2 layers of Protecta FR Wrap 50 mm wide × 1.8 mm thick, fitted flush with the exposed face of the fire seal.	No FRL can be provided.
F2 – PE pipe with an outer diameter of 90 mm and a pipe wall thickness of 2.8 mm	Ø 90 mm – pipe and intumescent cast into the fire seal	Pipe capping: U/U 100 mm thick Protecta Ex Mortar flush with the exposed face. 2 layers of Protecta FR Wrap 50 mm wide × 1.8 mm thick, fitted flush with the exposed face of the fire seal.	-/240/-
G1 – PE pipe with an outer diameter of 90 mm and a pipe wall thickness of 8.2 mm	Ø 90 mm – pipe and intumescent cast into the fire seal	Pipe capping: U/U 100 mm thick Protecta Ex Mortar flush with the exposed face. 2 layers of Protecta FR Wrap 50 mm wide × 1.8 mm thick, fitted flush with the exposed face of the fire seal.	-/240/240
G2 – PP pipe with an outer diameter of 90 mm and a pipe wall thickness of 8.2 mm	Ø 90 mm – pipe and intumescent cast into the fire seal	Pipe capping: U/U 100 mm thick Protecta Ex Mortar flush with the exposed face. 2 layers of Protecta FR Wrap 50 mm wide × 1.8 mm thick, fitted flush with the exposed face of the fire seal.	No FRL can be provided.
G3 – PVC pipe with an outer diameter of 90 mm and a pipe wall thickness of 6.7 mm	Ø 90 mm – pipe and intumescent cast into the fire seal	Pipe capping: U/U 100 mm thick Protecta Ex Mortar flush with the exposed face. 2 layers of Protecta FR Wrap 50 mm wide × 1.8 mm thick, fitted flush with the exposed face of the fire seal.	-/120/60